

---

## 2N-1 General Information for Design of Culverts

---

### A. Introduction

A culvert is a conduit under an embankment that transports stormwater from one side of the embankment to the other through hydraulic inlet, outlet, or barrel control. The primary purpose of a culvert is to convey surface water. However, when properly designed, it may also be used to restrict flow for upstream detention and reduce downstream storm runoff peaks. Primary considerations for the final selection of any drainage structure should be based upon appropriate hydraulic principles, economy, and minimal effects on adjacent property by the resultant headwater depth and outlet velocity. The allowable headwater elevation is the maximum elevation that can be reached before damage could be caused to adjacent property or compromise the right-of-way. It is this allowable headwater depth that is the primary basis for sizing a culvert.

The control of flow in a culvert can shift dramatically and unpredictably between inlet control, barrel control, and outlet control, causing relatively sudden rises in headwater. A critical aspect of culvert design is to determine stable and predictable performance for all expected flow levels. When the type of flow is known, the well-known equations for orifice, weir, or pipe flow and backwater profiles can be applied to determine the relationships between head and discharge (Blaisdell, 1966). Modern culvert nomographs, computer programs, and instructions are based on sound theory and extensive laboratory and field studies.

The 100-year flood is checked to determine if streets will provide access or be inundated. See Section 2A-4 that addresses access requirements for specific storms. Performance curves should be made available for all culverts for evaluating the hydraulic capacity of a culvert for various headwaters. These will display the consequence of high-flow rates at the site and any possible hazards. Sometimes a small increase in flow rate can affect a culvert design. If only the design peak discharge is used in the design, the designer cannot assess what effects any increases in the estimated design discharge will have on the culvert design. For culverts with significant headwater storage, the site should be treated as detention design, and flow should be routed.

### B. Definitions

**Backwater:** Constriction of flow causes a rise in the normal water surface elevation upstream of the constriction. The magnitude of the rise, in feet, is called backwater.

**Barrel control:** Barrel control for culvert hydraulics exists when the rise of headwater at the culvert inlet is greater than the rise from inlet or outlet control. This rise in headwater from barrel control can be a combination of barrel roughness, length, and restriction. Barrel control is rarely the control of headwater. Since the head loss due to roughness in the barrel is normally not as great as inlet head loss, the effect of barrel roughness is included as part of outlet control.

**Critical depth:** Critical depth can best be illustrated as the depth of water at the culvert outlet under outlet control at which water flows are not influenced by backwater forces. Critical depth is the depth at which specific energy of a given flow rate is at a minimum. For a given discharge and cross-section geometry, there is only one critical depth.

**Energy grade line:** The energy grade line represents the total energy at any point along the culvert barrel.

**Free outlets:** Free outlets are outlets with a tailwater equal to or lower than critical depth. For culverts having free outlets, lowering of the tailwater has no effect on the discharge or the backwater profile upstream of the tailwater.

**Headwater:** The vertical distance from the culvert invert (flow line) at the culvert entrance to the water surface elevation of the upstream channel.

**Hydraulic grade line:** The hydraulic grade line is the depth to which water would rise in vertical tubes connected to the sides of a culvert barrel. In a full flow, the energy grade line and the hydraulic grade line are parallel lines separated by the velocity head, except at the inlet and the outlet.

**Improved inlets:** Flared, improved, or tapered inlets indicate a special entrance condition that decreases the amount of energy needed to pass the flow through the inlet and, thus increases the capacity of culverts at the inlet.

**Inlet control:** With inlet control, the cross-sectional area of the culvert barrel, inlet geometry, and the amount of headwater or ponding at the entrance are the controlling design factors.

**Invert:** Invert refers to the inside bottom of the culvert.

**Normal flow:** Normal flow occurs in the channel reach when the discharge, velocity, and depth of flow do not change throughout the reach. The water surface profile and channel bottom slope will be parallel. This type of flow will be approximated in a culvert operating on a steep slope, provided the culvert is sufficiently long.

**Outlet control:** Outlet control involves the additional considerations over inlet control of the elevation of the tailwater, slope, roughness, and length of the culvert.

**Steep and mild slope:** A steep-slope culvert operation is where the computed critical depth is greater than the computed uniform depth. A mild-slope culvert operation is where critical depth is less than uniform.

**Submerged inlets:** Submerged inlets are those inlets having a headwater greater than 1.2 times the diameter of the culvert or barrel height.

**Submerged outlets:** Partially submerged outlets are outlets with tailwater that is higher than critical depth and lower than the height of the culvert. Submerged outlets are outlets having tailwater elevation higher than the soffit (crown) of the culvert.

**Tailwater:** The water depth from the culvert invert at the outlet to the water surface in the outlet swale or channel.

**Uniform flow:** Uniform flow is flow in a prismatic channel of constant cross-section having a constant discharge, velocity, and depth of flow throughout the reach. This type of flow will exist in a culvert operating on a steep slope, provided the culvert is sufficiently long.

## C. Site considerations

Site considerations include the generalized shape of the embankment, bottom elevations and cross-sections along the streambed, the approximate length of the culvert, and the allowable headwater elevation. In determining the allowable headwater elevation, roadway elevations and the elevation of upstream property should be considered. The consequences of exceeding the allowable headwater need to be kept in mind throughout the design process. See Section 2A-1.

## D. Culvert design items

The following should be considered for all culvert designs where applicable:

1. Engineering aspects
  - a. flood frequency
  - b. velocity limitations
  - c. buoyancy protection
2. Site criteria
  - a. length and slope
  - b. debris and siltation control
  - c. culvert barrel bends
  - d. ice buildup
3. Design limitations
  - a. headwater limitations (see Section 2A-1)
  - b. tailwater conditions
  - c. storage – temporary or permanent
4. Design options
  - a. culvert inlets
  - b. inlets with headwalls
  - c. wingwalls and aprons
  - d. improved inlets
  - e. material selection
  - f. culvert skews
  - g. culvert sizes and shapes
  - h. twin pipe separations (vertical and horizontal)
  - i. culvert clearances
5. Related designs
  - a. weep holes
  - b. outlet protection
  - c. erosion and sediment control
  - d. environmental considerations

The designer must incorporate experience and judgment to determine which of the above items listed need to be evaluated and how to design the final culvert installation.

## E. Design considerations

1. **Flood frequencies.** See Section 2A-1 for flood design frequencies.
2. **Velocity limitations.**
  - a. **Minimum cleaning velocity:** 3.0 fps
  - b. **Maximum velocity:** Should be consistent with outlet conditions of a stream or waterway. The need for channel stabilization at a culvert outlet is based on exceeding the natural stability of the channel.
3. **Buoyancy protection.** Headwalls, endwalls, slope paving, or other means of anchoring to provide buoyancy protection should be considered for all flexible culverts greater than 24 inches in diameter. Buoyancy is more serious with steepness of the culvert slope, depth of the potential headwater (debris blockage may increase headwater), flatness of the upstream fill slope, height of the fill, large culvert skews, or mitered ends.
4. **Length and slope.** Because the length of the culvert will affect the capacity of culverts on outlet control, the length should be kept to a minimum, and yet meet future needs and clear zones. Existing facilities should not be extended without determining the decrease in capacity that will occur. In addition, the culvert length and slope should be chosen to approximate existing topography. To the degree practicable, the culvert invert should be aligned with the channel bottom and the skew angle of the stream. The culvert entrance should match the geometry of the embankment. Future street or highway improvements need to be considered when setting the length of the culvert, especially in growth areas where rural cross-sections may be converted to urban sections, or street widening is a probability with sidewalks, utility corridors, etc.
5. **Debris control.** In designing debris control structures, it is recommended that the publication Hydraulic Engineering Circular No. 9 titled “Debris – Control Structures” (FHWA, 1971) be consulted. Debris control should be considered in the following conditions:
  - a. Where experience or physical evidence indicates the watercourse will transport a heavy volume of controllable debris
  - b. For culverts located in steep regions
  - c. For culverts that are under high fills
  - d. Where cleanout access is limited. However, access must be available to clean out the debris-control device.
6. **Siltation.** When streams or overland flow drain through culverts and carry siltation, it is important to design the culvert such that the culvert barrel will not be clogged with silt and reduce its capacity.
  - a. **Barrel slope.** The barrel slope of culverts should not have long sections of subcritical flow. This minimizes the settling of silt in the barrel. The slopes should be designed so the minimum velocity through the barrel will be no less than 3 fps for a 2-year storm frequency.

- b. **Horizontal bends.** A straight culvert alignment is desirable to avoid clogging, increased construction costs, and reduced hydraulic efficiency. However, site conditions may dictate a change of alignment. Horizontal bends may be used to avoid obstacles or realign the flow. When considering a nonlinear culvert alignment, particular attention should be given to maintenance access and erosion, sedimentation, and debris control. Certain culvert installations may encounter sedimentation problems. The most common of these problems are multi-barrel installations. Culverts with more than one barrel may be necessary for wide shallow streams and for low fills. It is well-documented that one or more of the barrels will accumulate sediment, particularly the inner barrel in a curved stream alignment – especially during times of low flow. However, self-cleaning usually occurs during periods of high discharge. This design situation should be approached cautiously with an increased effort in the field investigation stage to obtain a thorough knowledge of stream characteristics and bed-bank materials.
  
  - c. **Multiple pipe.** To help prevent siltation in low-flow conditions where multiple pipes are used, the inlet of all but one of the multiple pipes is placed higher than the other. The lower pipe can maintain cleaning velocities, and the higher pipes help provide flow capacity for major storms. The difference in elevation between the pipes is based on the depth of flow of the lower pipe for a 2-year storm frequency. The higher pipe is therefore at or above the 2-year frequency elevation in the lower pipe.
7. **Headwater limitations.** The allowable headwater (HW) elevation is determined from elevation of land use upstream of the culvert and the proposed or existing top of the embankment. Headwater is the depth (D) of water above the culvert inlet invert. In general, the constraint that gives the lowest allowable headwater elevation establishes the criteria for the hydraulic calculations.
- a. The allowable headwater design frequency conditions should allow for or consider the following upstream controls:
    - 1) Reasonable freeboard (see Section 2A-1 for maximum allowable headwater depth).
    - 2) Upstream property damage
    - 3) Elevations established to delineate floodplain zoning
    - 4) Low point in the road grade that is not at a culvert location
    - 5) Ditch elevation of the terrain that will permit flow to divert around culvert
    - 6) Follow recommended HW/D design criteria:
      - a) For drainage facilities with cross-sectional area equal to or less than 30 square feet, HW/D is equal to or less than 1.5
      - b) For drainage facilities with cross-section area greater than 30 square feet, HW/D is equal to or less than 1.2
    - 7) The headwater should be checked for the 100-year flood to ensure compliance with floodplain criteria.
    - 8) The maximum acceptable outlet velocity should be identified. The headwater should be set to produce acceptable velocities, or stabilization or energy dissipation should be provided where acceptable velocities are exceeded.

If there is insufficient headwater elevation available to convey the required discharge, it will be necessary to use a larger culvert, lower inlet invert, irregular cross section such as pipe arches or multiple pipes, improved inlet if in inlet control, multiple barrels, or a combination of these measures. If the inlet is lowered, special consideration must be given to scour and sedimentation at the entrance.

8. **Tailwater conditions.** The hydraulic conditions downstream of the culvert site must be evaluated to determine a tailwater depth for a range of discharges. At times, there may be a need for calculating backwater curves to establish the tailwater conditions. If the culvert outlet is operating with a free outfall, the critical depth and equivalent hydraulic grade line should be determined. Tailwater elevations can determine whether a culvert will operate with a free outfall or under submerged conditions. For culverts that discharge to an open channel, the stage-discharge curve for the channel must be determined.

If an upstream culvert outlet is located near a downstream culvert inlet or other control, the headwater elevation of the downstream control may establish the design tailwater depth for the upstream culvert. If the culvert discharges to a lake, pond, or other major water body, the expected high-water elevation of the particular water body may establish the culvert tailwater.

9. **Storage – temporary or permanent.** If storage is being assumed upstream of the culvert, consideration should be given to:
  - a. The total area of flooding.
  - b. The average time that bankfull stage is exceeded for the design flood; up to 48 hours in rural areas or 6 hours in urban areas.
  - c. Availability of the storage area for the life of the culvert through the purchase of right-of-way or easement.
10. **Weep holes.** Weep holes are sometimes used to relieve uplift pressure. Filter materials should be used in conjunction with the weep holes in order to intercept the flow and prevent formation of piping channels. The filter material should be designed as underdrain filter so that it will not become clogged and so that piping cannot occur through the pervious material and the weep hole. Plastic woven filter cloth would be placed over the weep hole in order to keep the pervious material from being carried into the culvert. If weep holes are used to relieve uplift pressure, they should be designed in a manner similar to underdrain systems.
11. **Erosion control at inlet and outlet.** Energy dissipation will be required for velocities higher than those outlined in Section 2O-2, Tables 3 and 4. Gabions or other erosion prevention or energy dissipation devices may be required.
12. **Erosion control along channel.** See Chapter 7 for specific information on channel/ditch lining. When pavement or riprap for side slope inverts are not used, nets, meshes, or geo-grids placed along the toe of the backslope of a paved channel bottom help prevent erosion of the bank and undermining of paved channels.
13. **Environmental considerations.** In addition to controlling erosion, siltation, and debris at the culvert site, care must be exercised in selecting the location of the culvert site. Environmental considerations are an important aspect of the culvert design. Using good hydraulic engineering, a site should be selected that will permit the culvert to be constructed to cause the least impact on the stream or wetlands. This selection must consider the entire site, including any necessary lead channels.

14. **Horizontal culvert clearances.**

- a. Small culverts (30 inches in diameter or less) should use an end section or a sloped headwall.
- b. Culverts greater than 30 inches in diameter should receive one of the following treatments:
  - 1) Extend to appropriate clear zone distance per AASHTO Roadside Design Guide
  - 2) When installing a grate to prevent entry, make sure to check the potential consequences of clogging and flooding.

15. **Separation of multi-pipe culverts.** In order to provide proper spacing between multi-pipe culverts, the following should be considered:

- a. **Without aprons.** If multi-pipe culverts are placed without aprons or footings, the distance between the centerline of each pipe should be 1-1/2 times the pipe diameter, but no less than 1 foot between the outside wall of each pipe. This separation allows room for compaction between the culverts. If a cutoff wall or barrier wall of low-permeability clay soil at least 2 feet thick is not available at the inlet and outlet to protect the pipe backfill, then consideration should be given to the use of flowable mortar as a means of pipe backfill.
- b. **With curtain walls.** The distance between the centerline of each pipe culvert with curtain walls equals the diameter plus 2 feet (allows for proper reinforcement placement in the footing).
- c. **With aprons.** The separation between multi-pipe culverts with aprons is based on the distance need between aprons. This distance should be a minimum of 2 feet from the end of the apron for concrete and reinforcement placement to tie the aprons together. A preferable distance of 4 to 6 feet should be used when earth fill is used.

## F. Pipe material

- 1. RCP – Minimum strength Class III under all streets and entrance pavement and Class V under railroad tracks and pipes to be jacked.
- 2. Use of CMP and multi-plate gauge is at the discretion of the Jurisdictional Engineer.

## G. Pipe culvert sizes

- 1. **Entrance pipes:** Minimum 18 inches in diameter
- 2. **Street or roadway pipe:** Minimum 24 inches in diameter

## H. Culvert inlets

Selection of the type of inlet is an important part of the culvert design, particularly with inlet control. Hydraulic efficiency and cost can be significantly affected by inlet conditions. The inlet coefficient  $K_e$  is a measure of the hydraulic efficiency of the inlet, with lower values indicating greater efficiency. All the methods described in this chapter directly or indirectly use inlet coefficients. See Table 1.

1. **Inlets with headwalls.** Headwalls may be used for a variety of reasons:

- Increasing the efficiency of the inlet
- Providing embankment stability
- Providing embankment protection against erosion
- Providing protection from buoyancy
- Shortening the length of the required structure

The relative efficiency of the inlet depends on the pipe material. Headwalls are usually required for all metal culverts and where buoyancy protection is necessary. Corrugated metal pipe in a headwall is essentially square-edged with an inlet coefficient of approximately 0.5. For tongue-and-groove or bell-and-spigot concrete pipe, little increase in hydraulic efficiency is realized by adding a headwall.

2. **Wingwalls and aprons.** Wingwalls are used where the side slopes of the channel adjacent to the entrance are unstable, or where the culvert is skewed to the normal channel flow. Little increase in hydraulic efficiency is realized with the use of normal wingwalls, regardless of the pipe material used and therefore, the use should be justified for other reasons. Wingwalls can be used to increase hydraulic efficiency if designed as a side-tapered inlet.

If high headwater depths are to be encountered, or the approach velocity in the channel will cause scour, a short channel apron should be provided at the toe of the headwall. This apron should extend at least one pipe diameter upstream from the entrance, and the top of the apron should not protrude above the normal streambed elevation.

Table 1: Inlet Coefficients

Type of Structure and Design of Entrance	Coefficient $K_e$
<i>Pipe, Concrete</i>	
Projecting from fill, socket end (groove-end)	0.2
Projecting from fill, square cut end	0.5
Headwall or headwall and wingwalls:	
Socket end of pipe (groove end)	0.2
Square-edge	0.5
Rounded [radius = 1/12 depth]	0.2
Mitered to conform to fill slope	0.7
*End-section conforming to fill slope	0.5
Beveled edges, 33.7° or 45° bevels	0.2
Side- or slope-tapered inlet	0.2
<i>Pipe, or Pipe-Arch, Corrugated Metal</i>	
Projected from fill (no headwall)	0.9
Headwall or headwall and wingwalls square-edge	0.5
Mitered to fill slope, paved or unpaved slope	0.7
End-section <sup>a</sup> conforming to fill slope	0.5
Beveled edges, 33.7° or 45° bevels	0.2
Side- or slope-tapered inlet	0.2
<i>Box, Reinforced Concrete</i>	
Headwall parallel to embankment (no wingwalls):	
Square-edged on three edges	0.5
Rounded on three edges to radius of 1/12 depth or beveled edges on three sides	0.2
Wingwalls at 30° to 75° to barrel:	
Square-edged at crown	0.4
Crown edge rounded to radius of 1/12 depth or beveled top edge	0.2
Wingwalls at 10° or 25° to barrel:	
Square-edged at crown	0.5
Wingwalls parallel (extension of sides)	
Square-edged at crown	0.7
Side- or slope-tapered inlet	0.2
<p><sup>a</sup> End section conforming to fill slope, made of either metal or concrete, are the sections commonly available from manufacturers. From limited hydraulic tests, they are equivalent in operation to a headwall inlet and outlet controls. Some end sections, incorporating a closed taper in their design, have superior hydraulic performance.</p>	
<p>Source: From Federal Highway Administration, Hydraulic Design of Improved Inlets for Culverts, Hydraulic Engineering Circular No. 13, 1972.</p>	

## I. Roadway or street overtopping

To complete the culvert design, roadway or street overtopping should be analyzed. See Section 2A-4 for allowable depth for major storms and cross-street flow allowable depths. A performance curve showing the culvert flow as well as the flow across the roadway is a useful analysis tool. Rather than using a trial-and-error procedure to determine the flow division between the overtopping flow and the culvert flow, an overall performance curve can be developed.

The overall performance curve can be determined as follows:

1. **Step 1:** Select a range of flow rates and determine the corresponding headwater elevations for the culvert flow. The flow rates should fall above and below the design discharge and cover the entire flow range of interest. Inlet- and outlet-control headwaters should be calculated.
2. **Step 2:** Combine the inlet- and outlet-control performance curves to define a single performance curve for the culvert.
3. **Step 3:** When the culvert headwater elevations exceed the roadway crest elevation, overtopping will begin. Calculate the equivalent upstream water surface depth above the roadway (crest of weir) for each selected flow rate. Use these water surface depths and the equation below to calculate flow rates across the roadway.

$$Q = C_d L(HW)^{1.5} \qquad \text{Equation 1}$$

where  $Q$  = overtopping flow rate (cfs);  $C_d$  = overtopping discharge coefficient;  $L$  = length of roadway (ft); and  $HW$  = upstream depth, measured from the roadway crest to the water surface upstream of the weir drawdown (ft).

4. **Step 4:** See Figure 1 for guidance in determining a value for  $C_d$ .
5. **Step 5:** Add the culvert flow and the roadway overtopping flow at the corresponding headwater elevations to obtain the overall culvert performance curve.

**Figure 1:** Determination of Overtopping Discharge Coefficient

From *Municipal Stormwater Management Manual, 2<sup>nd</sup> Edition, 2003, Thomas N. Debo, Andrew J. Reese*

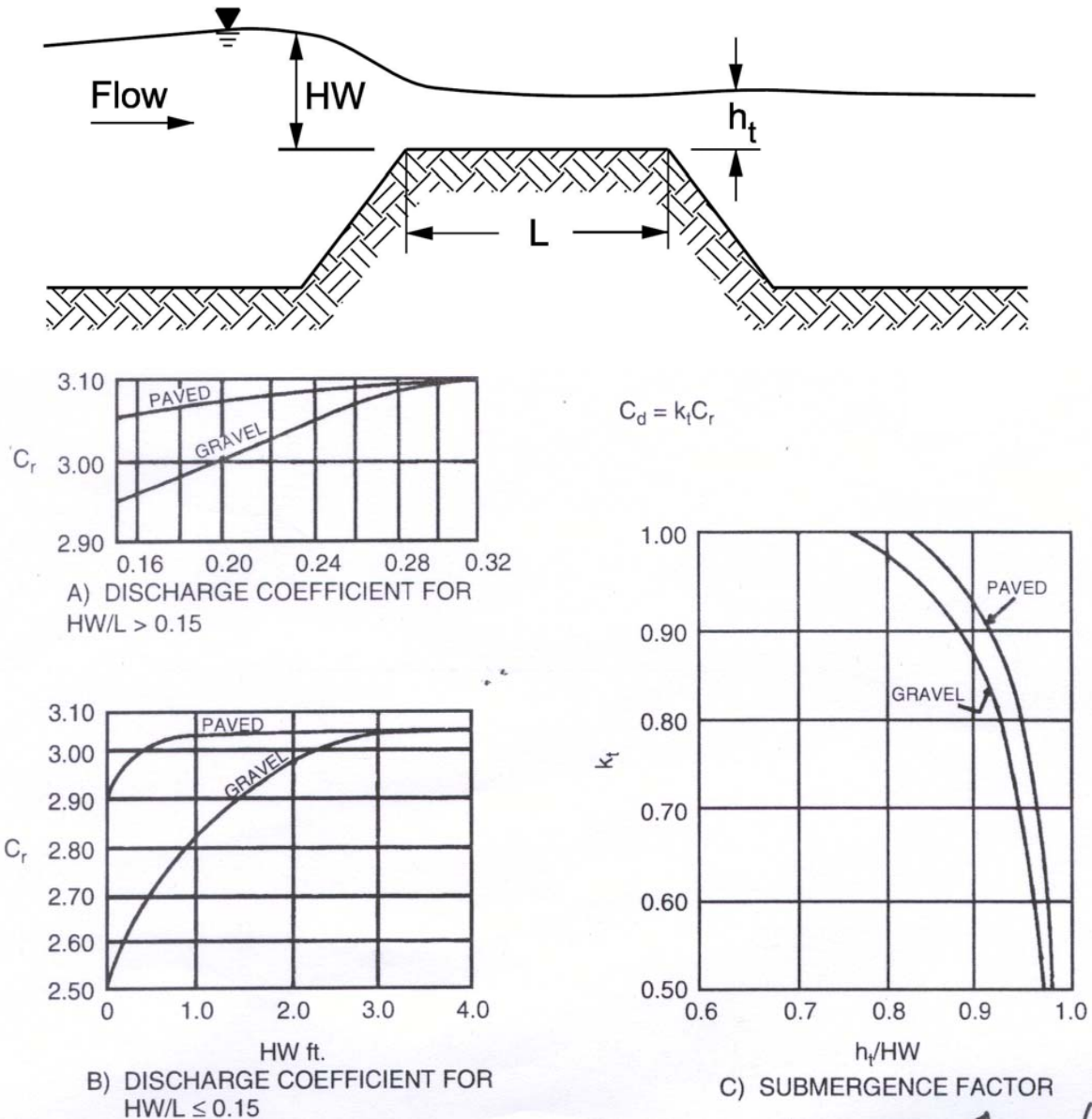

## J. Storage routing

A significant storage capacity behind an embankment attenuates a flood hydrograph. Because of the reduction of the peak discharge associated with this attenuation, the required capacity of the culvert and its size may be reduced considerably. If significant storage is anticipated behind a culvert, the design should be checked by routing the design hydrographs through the culvert to determine the discharge and stage behind the embankment. Routing procedures are outlined in HDS No. 5 (FHA, 1985). In addition, the HEC-RAS program may be used to analyze backwater conditions upstream of the culvert.

Flood routing design procedures through a culvert are the same as for a reservoir or detention basin. The site data and roadway geometry are obtained and the hydrology analysis completed to include estimating a hydrograph. Once this essential information is available, the culvert can be designed.