

# **An Overview of Scour Types and Scour-Estimation Difficulties Faced at Bridge Abutments**

**Robert Ettema, Tatsuaki Nakato, and Marian Muste**

IIHR ~ Hydrosience and Engineering

Department of Civil and Environmental Engineering

University of Iowa

Iowa City, IA 52242

robert-ettema@uiowa.edu

## **ABSTRACT**

The paper describes the range of scour types that may occur at bridge abutments, and addresses the extensive attendant difficulties confronting accurate estimation of abutment-scour depth. The difficulties, which include similitude aspects of laboratory experiments on scour at bridge abutments, complicate the development of reliable scour-estimation relationships. In a practical sense, the difficulties imply that estimation relationships can only be of approximate accuracy. They stem from the nature of the approach flow-field, the soil and sediment conditions at typical abutments, and thereby from the mix of scour and slope-stability failure processes potentially at play in the vicinity of bridge abutments. The full set of failure processes has yet to be determined and documented, and inevitably entails extensive investigative experiments using laboratory flumes. Arguably, the difficulties have muddled perceptions of scour extents observed at bridge sites, and have contributed to a certain level of skepticism regarding existing relationships used for scour-depth estimation.

**Key words: abutments—bridges—foundations—rivers—scour**

## **INTRODUCTION**

A particularly complex set of hydraulic engineering problems are faced when assessing the likelihood of scour of alluvial channels at bridge crossings, especially in the vicinity of bridge abutments located in compound channels. The complexities, and attendant difficulties, arise from considerations of the flow field, the varied sediments and soils, as well as from the mix of failure modes that may occur at and near abutments. Additionally, some of the complexities inevitably are difficult to replicate in a laboratory flume, and pose issues of hydraulic-modeling scale and similitude. It is small wonder that these complexities raise a concern that, relative to approach-flow depth or abutment dimensions, maximum values of local-scour depths observed in laboratory flume studies exceed values observed at actual abutments.

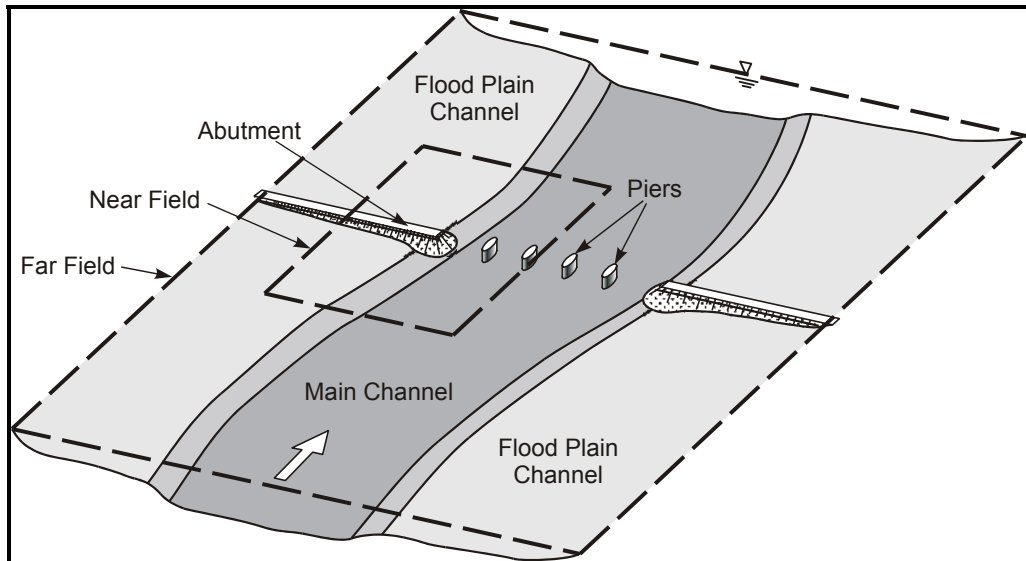
The present paper discusses the complexities and attendant difficulties in broad terms, addressing itself to the mix of scour processes that may occur at bridge abutments, and to the scale and similitude considerations attendant to hydraulic-modeling of scour. The complexities are under close consideration in a project the writer and colleagues currently are conducting at IIHR; the project is NCHRP 24-20, Prediction of Scour at Abutments. This project aims at producing reliable predictive relationships for scour estimation at bridge abutments. The relationships inevitably must be derived in large part from laboratory flume experiments. However, in planning and conducting such experiments, the writer and his colleagues immediately are confronted with the nettlesome issues incurred with reducing complex abutment situations to simplified, relatively tractable, yet practically meaningful flume experiments.

The first difficulty confronting flume experiments is assessment and replication of the complex flow field. A further difficulty is replication of the variable nature of the sediments and soils found at most abutment sites. These difficulties together greatly hamper estimation of abutment scour. Yet a further difficulty is appropriate scaling, via similitude considerations, of results obtained from laboratory flumes.

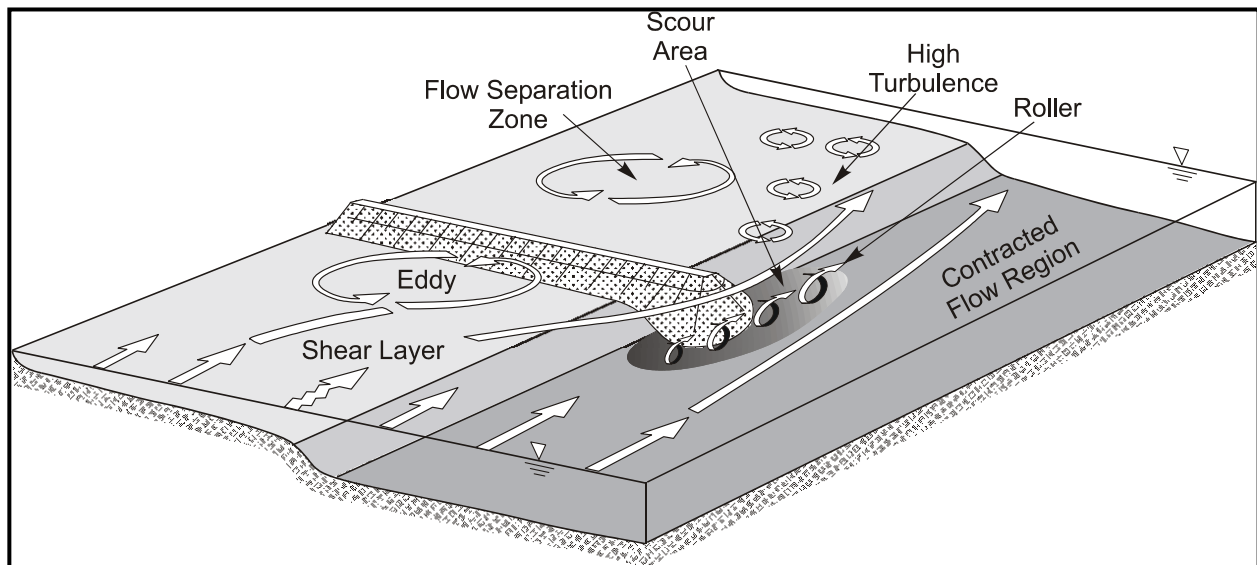
The sequence of figures given as Figures 1 and 2 illustrate the complexities faced when attempting flume experiments aimed at producing reasonably general and acceptably reliable prediction relations for estimating scour at abutments. Factors characterizing abutment-site morphology and sediment (and soil) conditions influence the flow field in the vicinity of an abutment the abutment site; producing a range of flow conditions. In turn, the flow field influences the type and extent of abutment failure that may occur.

## **FLOW FIELD**

To varying extents, most channels, natural or built, are compound in shape and/or roughness. As depicted in Figures 1 and 2, they comprise a central deeper portion flanked by side portions (floodplains) formed to aid conveyance of larger flows. Though substantial information exists regarding the flow field around an abutment in rectangular channel without a floodplain, little is known about the flow field formed at a floodplain abutment that is in close proximity to the main channel, as sketched in Figures 1 and 2. It is clear, though, that the near field of flow at an abutment is significantly influenced by the far field of flow.



**FIGURE 1. Overview of Far-Field and Near-Field of Flow in Abutment Vicinity**



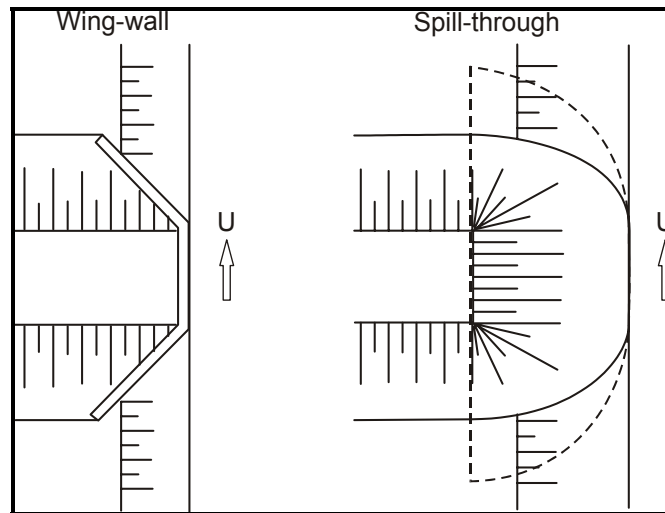
**FIGURE 2. Schematic of Near-Field Flow around an Abutment (Spill-Through Shape)**

Additionally, it is important to observe that, besides the overall complexity of flow field in compound channels, turbulence (its generation, dispersion, and decay) at a variety of scales is a prominent feature of the flow field, not only in the immediate vicinity of the abutment, but also at in the approach flow to the bridge. This flow feature poses a similitude difficulty for hydraulic modeling.

Fascinating composite flow interactions can occur between the floodplain and the main channel of a compound channels. The interactions involve exchange of flow between portions. They also involve the formation of large-scale turbulence and eddies in the shear layer developed in the flow region between the channel portions. By virtue of their protrusion into a compound-channel flow, abutments

significantly increase local complexity of flow field, as sketched in Figure 2, developed from flume experiments at IIHR. The flow field in the vicinity of an abutment is sensitive to circumstances of abutment geometry and setting in a compound channel. Additionally, the flow field evolves as the flow substantially scours the channel around the abutment. To date, there exists little information on the local flow field at an abutment for a situation such as shown in Figure 2.

As shown schematically in Figure 2, the flow field at an abutment typically comprises an acceleration of flow from the upstream approach to the most contracted cross section somewhere at or just downstream of the head of the abutment, followed by a deceleration of flow. A flow-separation region forms immediately downstream of the abutment, and flow expands around the flow separation region until it fully re-establishes across the compound channel. Just upstream of the abutment, a flow-separation point and a small eddy may develop (Figure 2). The size of the upstream eddy depends on the length and alignment of the abutment. The curvature of the flow along the interface between the stagnation region and the flow causes a secondary current that, together with the flow leads to a spiral motion or vortex motion like flow through a channel bend. The vortex in flow around an abutment head is more localized and it has a strong scouring action. The vortex erodes a groove along its path and it also induces a complex system of secondary vortices. At abutments with wing walls (Figure 3), the flow impinging on the wall may create a downflow (similar to at a bridge pier), which excavates a locally deepened scour hole at the wall. The effect of downflow is potentially reduced for spill-through abutments.



**FIGURE 3. Two Basic Shapes of Abutment: Wing-Wall and Spill-Through**

## FOUNDATION SOILS

Foundations at abutment sites may comprise sediment and soils quite varied in their constitution and erosion behavior. For compound channels, such as sketched in Figures 1 through 3, the soils comprising the floodplain likely differ in erosive behavior from the sediment forming the bed of the main channel. Floodplain soils likely contain greater amounts of fine sediment (silts and clays), and likely are more cohesive in character than main-channel sediment. The same may be said for soils forming the embankment and the abutment. The banks flanking the main channel attest to the greater strength of floodplain soils.

Much of the complexity confronting flume experiments aimed at replicating abutment situations as in Figures 1 and 2 revolves around simulating erosion of cohesive (or somewhat cohesive) soils forming the floodplain, simulating the geotechnical slope stability of the main-channel bank and the embankment, as well as simulating scour of the non-cohesive sediment comprising the bed of the main channel.

## SCOUR TYPES

Consequent to the variably complex nature of abutment flow fields and sediments and soils, several types of scour may lead to abutment failure. Field observations show that all have occurred. Figures 4 through 8 illustrate several scour-related processes that may occur at spill-through abutments (possibly, a parallel set of figures could be prepared for wing-wall abutments, though such abutments are more common for small rivers and streams). The scour types can be summarized as follow:

### Type I, abutment in single channel (no floodplain)

- (I-a) Abutment threatened by local scour of main-channel bed (Figure 4)
- (I-b). Abutment threatened by local scour and contraction scour of main-channel bed (not illustrated)

### Type II, abutment on floodplain (to varying extents)

- (II-a) Abutment threatened directly by scour (local and constriction) of main channel (Figure 5)
- (II-b) Abutment threatened by collapse of main-channel bank consequent to scour (local and constriction) of main-channel bed (Figure 6)
- (II-c) Abutment threatened by scour of floodplain (Figure 7)
- (III-d) Abutment threatened by embankment erosion (Figure 8)

The scour types may result from several flow conditions:

1. General scour of the main channel bed. It occurs in response to an overall propensity of the main-channel flow to degrade should an imbalance of sediment supply along the channel occur.
2. Change in main channel alignment and morphology, which adversely affects abutment location and orientation relative to flow in the main channel (e.g., a meander-loop migration may direct flow adversely towards an abutment).
3. Contraction scour of the main channel (and possibly a part of the floodplain channel) at the abutment site. Flow, constricted at the abutment site, locally scours the site, until a new balance is established between flow and bed. Contraction scour can be severe in situations where a long embankment to a bridge abutment intercepts flow over a floodplain; the intercepted flow is funneled through the abutment site.
4. Local scour attributable to the local flow field at an abutment.
5. Contraction scour of the floodplain at the abutment. Flow on the floodplain adversely impinges against the approach embankment.

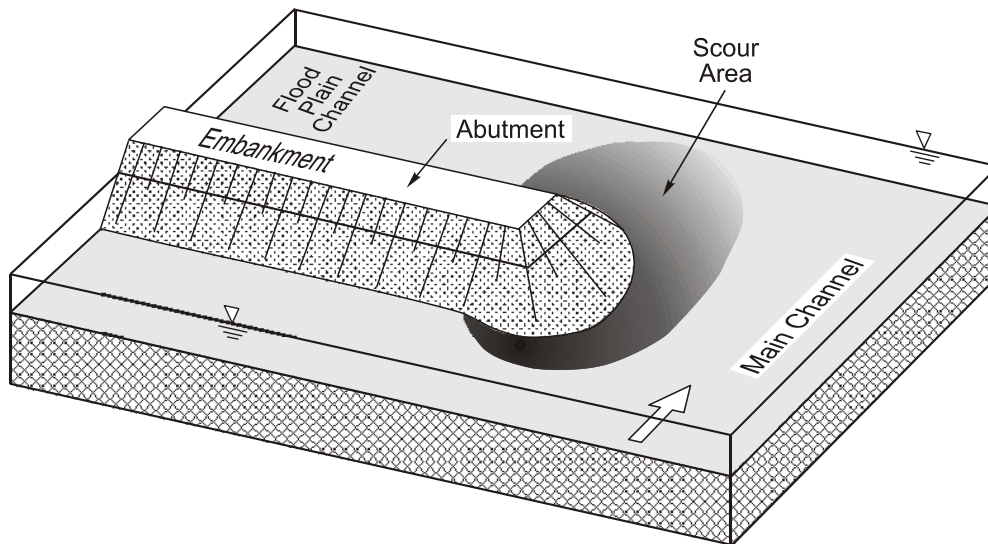
A complication for flume studies and for developing reliable predictive relationships, is that these scour processes may occur at the same time, and therefore be difficult to estimate reliably (notably Types I-a and –b, and II-a and –b). Additional factors, such as variable vegetation cover and roughness of the floodplain, complicate the flow conditions.

For scour Types I-a and -b (Figure 4), abutments are threatened by scour of the main-channel bed, and by direct entrainment of material from the abutment face. The deepening scour hole may pose a slope-stability problem for the abutment. Failure, to varying extents, relates to extent of abutment-slope failure and washout. The scour may be attributed (depending on abutment length and channel width) to the combined effects of local and contraction scour processes. So far, most flume experiments have investigated this category. The simplest (relatively speaking) sub-category of this scour type is that for a rectangular abutment, or a wing-wall abutment, sited in a uniformly deep alluvial channel. In that case, abutment failure occurs when scour undermines, or reduces support for, the abutment's foundation. Most flume experiments so far have investigated this condition (e.g., as summarized in reference [1]).

One or more of several possible scour types may occur for abutments on, or protruding from, floodplains. Type II-a (Figure 5), illustrates essentially the same scour process as in category I-a, except that the presence of a floodplain may alter the flow field at the abutment.

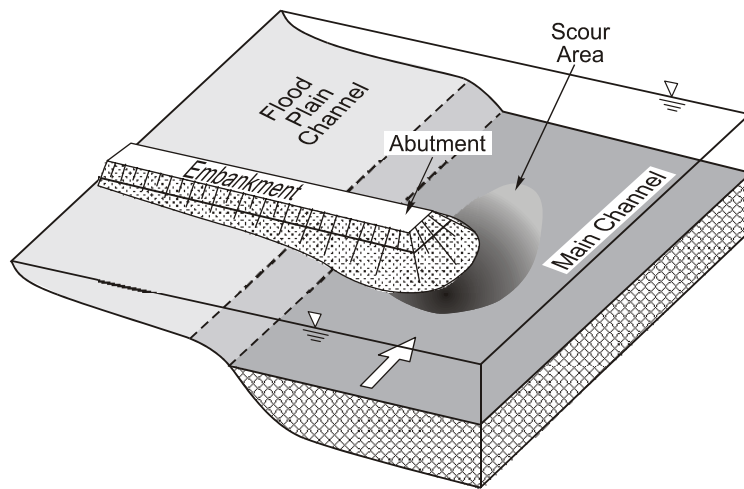
Scour Type II-b (Figure 6) has received little attention, but may be common for bridges. Here, the abutment is threatened by a geotechnical failure of the main-channel bank. The failure is triggered by scour of the main channel bed at the bank. The scour could be caused by a combination of local as well as contraction scour processes, and by main-channel shifting.

Type II-c (Figure 7) is scour of the floodplain immediately at the abutment. And, Type II-d (Figure 8) is erosion of the embankment approach to the abutment.

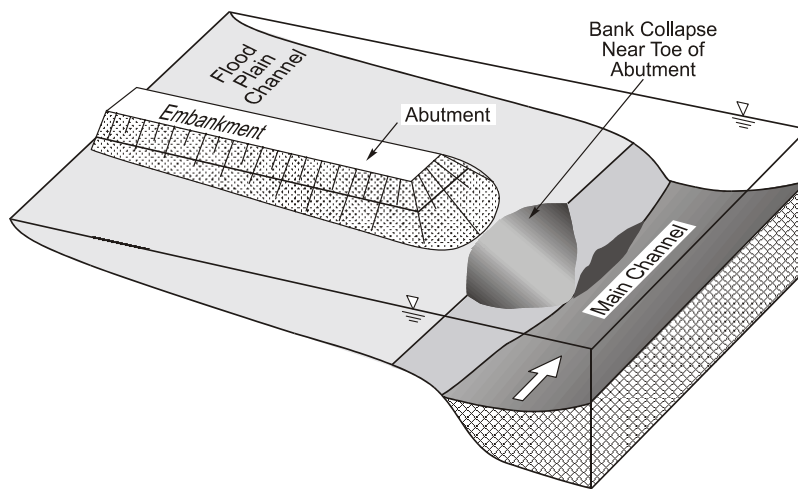


**FIGURE 4. Scour Type I-a, Abutment Threatened by Scour of Main-Channel Bed**  
**(Note: scour Type I-b may include additional effect of contraction scour.)**

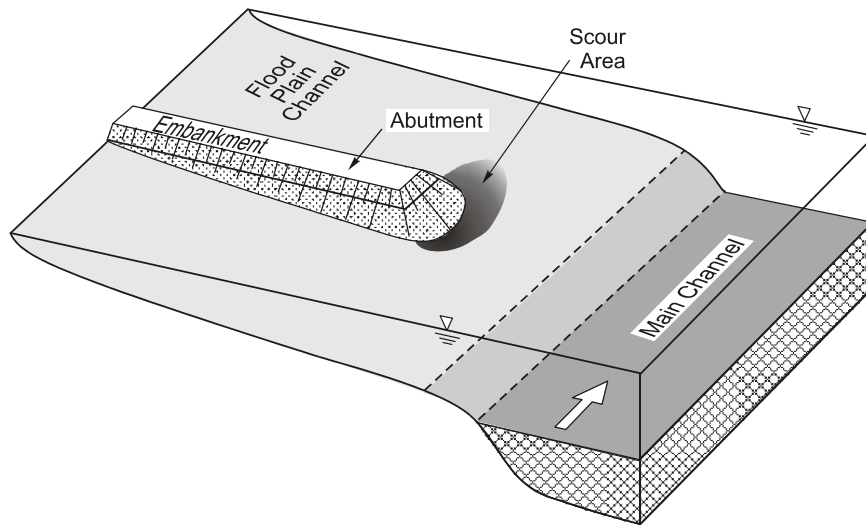
The gallery of scour processes illustrated in Figures 4 through 7 poses considerable modeling complexities for laboratory flume investigation of abutment scour. Note that these figures depict abutment circumstances uncluttered by the additional ad-hoc complications attributable to variable vegetation, or presence of an adjacent pier or an entire other bridge, or other features (e.g., debris) influencing the abutment flow field.



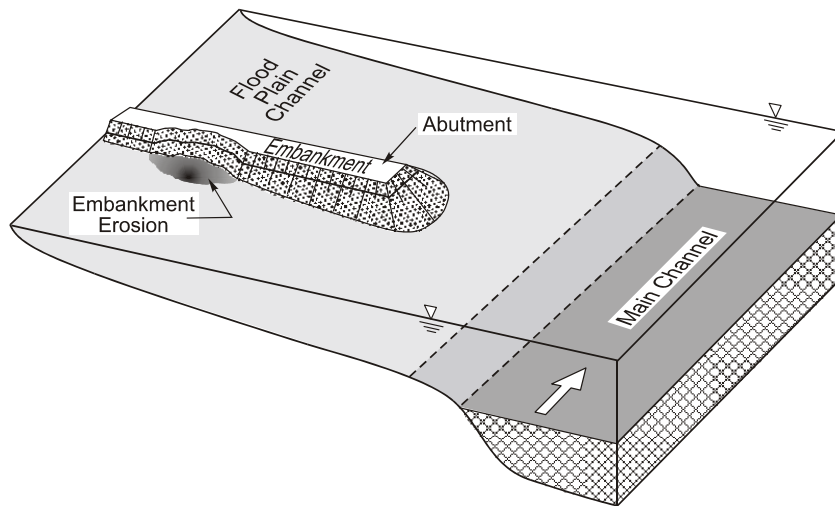
**FIGURE 5. Scour Type II-a, Abutment Threatened by Scour of Main-Channel Bed**



**FIGURE 6. Scour Type II-b, Abutment Threatened by Collapse of Main-Channel Bank Consequent to Scour (Local and Constriction) of Main-Channel Bed**



**FIGURE 7. Scour Type II-c, Abutment Threatened by Scour of Floodplain**



**FIGURE 8. Scour Type II-d, Abutment Threatened by Scour of Embankment**

### **SIMILITUDE DIFFICULTIES**

Limitations in hydraulic-model similitude hamper the capacity of flume experiments to directly replicate many of the complexities of soil/sediment and flow conditions at abutment sites, and thereby to reproduce the abutment-failure processes shown in Figures 4 through 8. The similitude limitations stem directly from the material properties of water as well as sediment and soils. The limitations must be recognized then worked around. Presently, the leading publications on scour do not take into account the appropriate similitude concerns (e.g., references [2, 3, 4, 1]),

## **Sediments and Soils**

The essential difficulties concern simulating scour of cohesive sediment and simulating slope stabilities (of main-channel bank, and of abutment and approach embankment). These difficulties especially face flume experiments intended for investigating abutments prone to Type II failures; though, actually they face all experiments on spill-through abutments, because failure of those abutments seems predominantly to occur as slope instability and collapse consequent to scour of the main channel or floodplain at the base of the abutment.

The practical limitations in simulating cohesive sediment also limit direct hydraulic modeling of slope failure (unless the slope is formed of non-cohesive sediment). Those limitations greatly complicate flume investigation of scour category Types II-c and II-d.

## **Flow-Field**

Two not unrelated considerations complicate flume experiments of abutment scour. One consideration concerns the extent of far-field flow to be encompassed in the experiment setup. The other, a more fundamental issue, concerns flow-field similitude, notably simulation of shear stresses as well as pressures.

Flume experiments must balance considerations of extent of flow-field to be simulated, and the balance of forces acting on the flow. A difficulty is that abutment layout and size, as well as the pertinent extent of approach-channel bathymetry together with the non-uniform and the complexly turbulent nature of the approach flow (e.g., as sketched in Figure 2), and similitude constraints, require that hydraulic models of abutments practically be far-field models that encompass a substantial area of the approach channel, yet also be large enough in size as to facilitate accurate replication of flow forces. This composite requirement confronts investigators with the need to use a large (especially wide) flume for investigating Type II scour categories.

Recent work at IIHR infers that a substantial scale effect occurs in loose-bed modeling whose similitude primarily is based on intensity of bed sediment movement is used as the primary criterion for similitude, as elaborated briefly below. Ettema and Muste (5) also show that elevated levels of turbulence in models significantly affect flow distributions in small-scale models of dikes and wingdams. Not only does exaggerated Froude number result in increased stagnation-pressure heads, it amplifies the effect of centrifugal acceleration in regions of curved flow.

## **CONFRONTING THE DIFFICULTIES**

The difficulties discussed above presently face the writers embarked on NCHRP Project 24-20, whose objectives are to improve reliability of abutment-scour prediction, especially for abutments straddling floodplains. The writers are configuring a plan of study that aims to address, and to work around, them. Early issues in preparing the plan, which involves extensive flume experiments, are –

1. What scour processes are pertinent?
2. How to design effective experiments for elucidating the pertinent scour processes?
3. What levels of scour-prediction accuracy are practical and even meaningful?

Preparation of the plan has involved the following series of tasks:

1. Select the most important and common scour types for spill-through and wing-wall abutments;
2. Design experiment setups for replicating the selected scour types;
3. Define the flow-field associated with each scour type;
4. Conduct parametric investigation of scour depths and extents incurred with each scour type.

Floated below for audience/reader comment are the scour types selected and the commensurate flume experiments contemplated. The experiments will be conducted in two flumes, one being 5-m wide, and the other 2.5-m wide.

### **Scour Types**

The scour types identified to be of highest importance are Types II-a and -b (Figures 5 and 6). Also important, but somewhat less so, is Type I (Figure 4). These scour types should be investigated for through-flow and wing-wall abutment forms.

### **Flume-Experiments**

Three basic series of experiments are centrally required. Of them, Type I scour (Figure 4), is relatively straightforward to set up in a flume, and for which quite a few prior studies have been conducted. This series can be conducted at a range of scales, and used to ascertain scale effects.

Flume experiments on Types II-a and -b scour can be investigated using a flume fitted with a fully rigid floodplain with an alluvial (erodible) main channel. The simplifying assumption used here is that the floodplain is much less erodible than the bed of the main channel. The experiments would seek to determine the extent of scour in the main channel adjacent to the abutment, but would not go so far as to replicate bank failure. The objective of the experiments would be to provide a predictive relationship for maximum depth of main channel scour. Predictions of scour depth would be given to a geotechnical engineer, who then would estimate the stability of the main-channel bank. The experiments should entail varying abutment-head location relative to the edge of the main channel. Additionally, they may entail varying abutment orientation relative to the main channel.

A variation of flume setup involving a rigid floodplain is to fit an erodible sediment recess around abutment head. The remainder of the floodplain could still be kept rigid. This setup would be used to investigate possible interaction between scour in the main channel and scour on the floodplain around the abutment.

As the flow field for scour type illustrated in Figures 5 and 6 is not adequately known, flow-field delineation is a necessary precursor task before determining predictive relationships. It is especially necessary for abutments situated on floodplains. Of prime interest in this respect are situations where the abutment is in close proximity to the main channel. In these situations, scour likely results as the combined impact of flow contraction and the flow features generated by the abutment itself.

### **CLOSING REMARKS**

Many bridge abutments are located in compound channels whose morphology (alignment, bathymetry) is fairly complex. Additionally, many bridge abutments are located in situations where the channel is formed of various materials, occupying different locations within a bridge site. Non-cohesive sediments may form the bed of a main channel; silts and clay may predominate in

riverbanks and underlying floodplains; and rocks may have been placed as riprap protection for the abutment, as well sometimes along adjoining riverbanks.

The scour-estimation relationships and guidelines presently available do not adequately take into account the complexities of channel morphology and sediment/soil disposition. Given the complexities described in this paper, the writer believes that scour-prediction relationships should aim at a level of practical approximation, whereby bridge designers may estimate reasonable upper-bound extents of scour produced by overall general (and somewhat simplified) conditions of scour; e.g., as illustrated in Figures 4 through 8. Bridge designers should be aware of the influences on scour of additional important factors such as proximity of other structures and of, say, floodplain vegetation. To include many of those factors in a predictive relationship is a Herculean task that likely cannot be completed satisfactorily.

The flume experiments outlined above aim at investigating several general, though simplified, conditions of scour at abutments. The experiments confront some scour complexities (e.g., influence of similitude), and hopefully sidesteps others (e.g., slope stability). The writer is curious to learn if the conference audience concurs with the flume-experiment approach outlined herein.

## ACKNOWLEDGMENTS

The work described herein is being conducted under NCHRP project 24-20, Prediction of Abutment Scour.

## REFERENCES

1. Melville, B.W. and S.E. Coleman. *Bridge Scour*. Water Resources Publications, 2000.
2. Richardson, E.V., L.J. Harrison, and S.R. Davis. *Evaluating Scour at Bridges*. Report No. FHWA-IP-90-017 HEC 18. Federal Highway Administration, U.S. Department of Transportation, Washington, D.C., 1991.
3. Richardson, E.V., and S.R. Davis. *Evaluating Scour at Bridges*. Publication No. FHWA HI-96-031, HEC 18. Federal Highway Administration, U.S. Department of Transportation, Washington, D.C., 1995.
4. Sturm, T.W. Abutment Scour in Compound Channels. *Stream Stability and Scour at Highway Bridges*. American Society of Civil Engineers, Reston, Virginia, 1998, p. 443.
5. Ettema, R., and M. Muste. *Flume Study of Scale Effects in Hydraulic Models of Flow around Dikes*. IIHR Report 342. Waterways Experiment Station, U.S. Army Corps of Engineers, Vicksburg, 2002.