

J.D. Doornink
Department of Civil and Construction Engineering
Iowa State University

USE OF RAILROAD FLATCARS IN LOW-VOLUME ROAD BRIDGES

Submitted October 18, 2002

Author: Justin D. Doornink
Graduate Student/Research Assistant
Iowa State University
Department of Civil and Construction Engineering
407 Town Engineering Building
Ames, IA 50011-3232

Phone: (515) 294-5419
Fax: (515) 294-7424
Email: jdoornin@iastate.edu

Text = 3,782 words

11 Figures = 2,750 words

Total Word Count = 6,532 words

ABSTRACT

The use of Railroad Flatcars (RRFCs) as the superstructure on low-volume county bridges has been investigated in a research project at Iowa State University. These alternative bridges enable county engineers to replace old, inadequate county bridges for less money and in a shorter construction time than required for a conventional bridge. Thus, saved capital can be used to improve other areas of secondary road transportation.

A feasibility study completed in 1999 by the Bridge Engineering Center of Iowa State University determined that RRFC structures can have adequate strength to support Iowa legal traffic loads. In a follow-up research project, two RRFC demonstration bridges with different substructures and RRFC lengths were designed, constructed, and tested to validate the conclusions of the feasibility study.

Bridge behavior predicted by grillage models for each bridge was supported by data from field tests, and it was found that the engineered RRFC bridges have live load stresses significantly below the safe yield strength of the steel, and deflections well below the AASHTO Bridge Design Specification limits. Based on the results of this research, it has been determined that through proper RRFC selection, connection, and engineering design, RRFC bridges are a viable, economic alternative for low-volume road bridges.

INTRODUCTION

Approximately eighty-one percent of Iowa's 25,000 bridges are on secondary roads, and thus, are the responsibility of the counties. The number of bridges in Iowa ranks 5th in the nation while Iowa's population ranks 30th. Therefore, the state's tax base is limited, and as a result, Iowa county engineers have inadequate funds to properly address the secondary road bridge problems. As a result, the Bridge Engineering Center of Iowa State University (ISU) investigated the feasibility of using railroad flatcars (RRFCs) as the superstructure on low-volume county bridges. Railroad flatcars offer several attractive characteristics that make them desirable for superstructures; they are easy and quick to install, can be used on existing or new abutments, are available in various lengths, require low maintenance, and are relatively inexpensive. In 1999, results from the feasibility study indicated that properly designed RRFC bridges can handle Iowa legal loads for a tandem truck (1).

Addressing the recommendations from the 1999 ISU feasibility study, a follow-up research project was initiated in 2000 to design and construct two RRFC demonstration bridges. Buchanan and Winnebago Counties in Iowa expressed interest in using the RRFC bridge concept since it was envisioned that a completely new RRFC bridge could be constructed for less than one half the cost of a conventional structure. Therefore, the objectives of the follow-up research were to (1) develop a process for selecting structurally adequate flatcars, (2) develop design and construction guidelines for these alternative LVR bridges, and (3) the design, construction, and testing of two demonstration bridges. The following tasks were undertaken to meet the research objectives:

1. Thorough inspection and selection of readily available decommissioned RRFC's.
2. The construction and laboratory testing of a connection specimen that simulated a connection between RRFC's.
3. Design and construction of two RRFC demonstration bridges with different types of flatcars, span lengths, and substructures.
4. Field tests of the RRFC's before and after the flatcars were connected together.
5. Comparison of theoretical and experimental results.

This paper will focus on the construction, testing, and theoretical analysis of the bridges. For a more complete report including details of RRFC selection, demonstration bridge designs, and detailed analysis of the laboratory specimen, refer to the report prepared for the Iowa Department of Transportation (2).

BRIDGE DESIGN AND CONSTRUCTION

Through inspection of 4 types of RRFCs, it was possible to establish guidelines for visually selecting flatcars for use on bridges. Using these guidelines, one type of flatcar was selected for each bridge, and a simplified grillage analysis was used to verify each RRFC's adequacy for use on a LVR bridge. Through this process, it was determined that the 56-ft (17.1-m) v-deck style RRFC shown in Figure 1 and the 89-ft (27.1-m) style in Figure 2 were the best flatcars for the Buchanan County Bridge (BCB) and the Winnebago County Bridge (WCB), respectively.

In addition to investigating two different RRFC's as superstructures, it was possible to design, construct, and investigate different substructures as well as RRFC connections in the bridges. Details of each bridge are presented in the following sections.

Buchanan County Bridge

The flatcars for the Buchanan County Bridge (BCB) were supported at their ends on 3-ft (91.4-cm) square, concrete cap beams with backwalls; each cap beam was supported by five HP 10x42 steel piling. The use of concrete in the substructure allowed for an integral abutment at one end of the bridge with an expansion joint at the other end; the concrete also formed the backwall. Longitudinal flatcar connections

were installed between the flatcars to help distribute traffic loads effectively among the three RRFC's. The connections were constructed by spacing the flanges of the exterior members on adjacent flatcars 6 in. (152 mm) apart. Then, longitudinal reinforcement bars totaling 4.12 in.² and concrete were used to fill the void by forming a reinforced concrete beam. Transverse threaded rods spaced 24 in. (610 mm) on center were included to hold connection together. To ensure that the longitudinal connections supported their own self weight, midspan shoring was used during construction of the connections, which reduced the dead load being distributed to the steel structural members. After structurally connecting the RRFC's, a layer of pea gravel was placed on the RRFC's to facilitate deck drainage. This was followed by installation of an asphalt milling driving surface approximately 5.5 in. (140 mm) and 9.0 in. (229 mm) deep at the edges and middle of the bridge (with respect to the tops of the flanges on the exterior members). Finally, a guardrail was added. In Figure 3(a) a profile view of the BCB is presented; a midspan cross-section with some details of the longitudinal flatcar connection is illustrated in Figures 3(b) and 3(c).

Winnebago County Bridge

The second RRFC demonstration bridge was a three span structure because preliminary calculations determined that the 89-ft RRFCs required a shorter clear span. Therefore, the 89-ft (27.1-m) flatcars were supported by steel-capped piers and abutments at the RRFCs' bolsters and ends, resulting in a main span of 66 ft (20.1 m) – a reduction of 23 ft (7 m). The use of steel as the substructure saved construction time by eliminating the need for concrete formwork and curing time. A sheet pile wall provided roadway support at each abutment. For connection between the RRFC's, the top half of the exterior members above the deck surface was removed for exterior members in the connection, and longitudinal plates were welded to the top and bottom of adjacent flatcars to form a structural tube. Next, the tube was reinforced with transverse threaded rods on approximately 24 in. (610 mm) centers and a single #5 longitudinal reinforcement bar (added for crack control), after which it was filled with concrete. After connecting the flatcars, the south ends of the RRFCs were welded to the abutment to restrain vertical and horizontal translation, and expansion joints (which prevented vertical deflection) were added to the north ends of the RRFCs, and on each pier. Next, recycled timber planks were positioned transversely and connected to the flatcars to help provide transverse load distribution, which was not the case with the BCB. A gravel driving surface was then placed on top of the timber planks, and finally a guardrail system was installed. Figure 4(a) illustrates the profile of the WCB, and Figure 4(b) presents a midspan cross-section with a few details of the longitudinal connections.

RRFC BRIDGE PERFORMANCE

In order to investigate bridge behavior, each RRFC bridge was load tested with tandem trucks carrying Iowa legal loads (gross weights are given later), respectively. On each bridge, Load Test 1 (LT1) was performed after the flatcars were placed on the abutments and/or piers, but before the longitudinal flatcar connections between flatcars were in place. Load Test 2 (LT2) was performed immediately after construction of the bridge completed. In each test, strains and deflections from the truck loads were measured and recorded at several critical longitudinal locations on the bridges.

Buchanan County Bridge Results

LT1 consisted of 4 tests on the center RRFC with no connection between the flatcars; the tandem truck used for the testing had a gross weight of 51,000 lbs, respectively. Since the tandem wheel base width (outside-outside of tires) was only 18.5 in. (470 mm) narrower than the width of the RRFC, it was only possible to position the test truck approximately 9.25 in. (235 mm) eccentric to the longitudinal centerline of the RRFC. As a result, two tests were conducted with the test truck centered on the RRFC, and two other tests were performed with the test truck transversely eccentric at the north and south edges of the RRFC. In Figure 5, the maximum midspan displacements that were measured in LT1 tests are presented. These displacements occurred when the centerline of the tandem axle was at the midspan of the bridge.

As previously noted, strains were also measured in all tests; however, only deflection results are presented in this paper. Comparison of the results from the 4 tests in LT1 revealed the following:

- The interior girder's vertical deflections (and strains) remained nearly the same in all tests since the eccentric loading was so small.
- When comparing the deflections in Tests 1 and 4 with those in Tests 2 and 3, the discrepancy among the results was less than 0.13 in. (3.2 mm). In addition, displacement patterns for Tests 2 and 3 are nearly mirrored images of each other across the longitudinal centerline of the RRFC. This behavior indicates that the RRFC's have excellent, consistent torsional stiffness.
- The maximum deflections on the primary, interior and exterior members were approximately 0.40 in. (10 mm) and 0.50 in. (13 mm).

LT2 tests were performed with the longitudinal connections in place between the three RRFC's. To investigate if the asphalt milling driving surface had any effect on transverse load distribution, identical tests were performed with test trucks positioned in several transverse locations before and after the driving surface was installed. Installation of the driving surface had minimal effect on strains, deflections, and thus, transverse load distribution. Figure 6 illustrates the primary truck positions relative to the RRFC's in LT2 and presents midspan deflections for each test after the installation of the driving surface. "Truck A" and "Truck B" were load with 51,500 lbs and 52,000 lbs, respectively. By reviewing the deflections in Figure 6, the following observations can be made about LT2 bridge behavior:

- Deflection patterns for Tests 1, 5, and 6 reveal symmetrical deflection behavior, while Tests 2 and 3 illustrate mirror deflection patterns across the longitudinal centerline of the bridge. Thus, the bending and torsional stiffness of the RRFCs with longitudinal connections remains consistent transversely across the bridge.
- The south and north edges of the bridge deflected upward during Tests 2 and 3, and thus, indicating that the longitudinal flatcar connections are structurally adequate.
- Comparison of deflection (and strain) results for the center RRFC loaded with a transversely centered test truck showed that the addition of the two additional RRFCs that were connected to the center RRFC as previously described reduced strains in the three primary longitudinal members of the flatcar in the range of 45-55%, while deflections were reduced by between 55-60%. This behavior documented the effectiveness of the reinforced connections between adjacent flatcars.

An ASTM coupon tensile test was performed on a piece of steel from the 56-ft (17.1-m) flatcar. From this test, the proportional limit and modulus of elasticity from the stress-strain diagram were determined to be 40 ksi (275 MPa) and 29,000 ksi (200,000 MPa), respectively. Thus, a conservative yield strength was assumed to be 36 ksi (248 MPa). Using this value, it was determined that the maximum flexure stresses in the primary, longitudinal members of the finished bridge from these tandem truck loads were approximately 4.6 ksi (31.7 MPa). In addition, the maximum deflection was measured to be 0.38 in. (9.7 cm) as shown in Figure 8. According to the 1994 LRFD (3) and 1996 LFD (4) AASHTO Bridge Design Specifications, the maximum allowable deflection should not exceed 1/800 of the span length, which is 0.84 in. (2.13 cm) for a 56-ft (17.1-m) span. Thus, maximum stresses were significantly below the yielding strength of the steel, and deflections were within safe limits.

Winnebago County Bridge Results

LT1 consisted of 5 tests with no connection between the RRFCs - 3 tests with the RRFC's unrestrained at the abutments and 2 tests after the addition of the expansion joint and pinned restraint at the north and south abutments. Each test was performed with the test truck grossly loaded with 52,200 lbs,

respectively, on the middle RRFC; since the tandem wheel base width was close to the same width of the flatcar, it was not possible to eccentrically load the 89-ft (27.1-m) flatcars.

LT2 tests were performed with longitudinal flatcar connections between the three RRFCs, and the transverse timber planks and gravel driving surface in place. Four primary truck positions shown in Figure 7 were investigated; in a given test, the tandem truck with a gross load of 52,300 lbs, respectively, was positioned transversely as shown and data were collected with the truck in several longitudinal locations. Midspan deflections measured for each of the four truck positions in LT2 are also presented in Figure 7. Reviewing the data in this figure, the following observations can be made:

- Deflections for Tests 1 and 3 are nearly symmetrical about the longitudinal centerline of the bridge, which indicates effective transverse load distribution due to the longitudinal connections and timber decking.
- Deflection results for Tests 2 and 4 reveal the relationship between the truck speed and bridge deflections. The deflection pattern is the same for both tests; however, the deflections were approximately 18% larger with the truck traveling at 30 mph (48 km/hr).

In Figure 8, the midspan deflections that occurred when the centerline of the tandem axle was at the midspan of the bridge for LT1 and for a transversely centered truck in LT2 are compared. Figure 8 illustrates the following:

- Comparison of the results from the 5 tests of LT1 (results from only one test have been included in the paper) revealed that the addition of abutment restraints reduced midspan strains by approximately 6% and deflections by 0.10 in. (2.54 mm).
- Deflections for LT1 at midspan were only measured on the middle girder and the west edge of the center RRFC; the deflection of the east edge of the center RRFC was assumed to be the same as at the west edge, and is so indicated. By comparing the results presented in Figure 10, the deflection of 1.16 in. (29 mm) obtained in LT1 was reduced to 0.36 in. (9 mm) in LT2, a reduction of approximately 70%. Review of midspan strains in the two tests also showed similar reductions.

Through another ASTM tensile coupon test, it was found that the steel on the 89-ft (27.1-m) RRFC had the same yield strength and modulus of elasticity as the 56-ft (17.1-m) RRFC. When looking at the overall performance of the 89-ft (27.1-m) completed bridge, it was determined that the maximum flexural stresses in the primary, longitudinal members from legal traffic loads were approximately 7.1 ksi (48.8 MPa). In addition, the maximum deflection was measured to be 0.63 inches (16 mm) as shown on Figure 7. For the 66-ft (20.1-m) span, according to the 1994 LRFD and 1996 LFD AASHTO Bridge Design Specifications, the maximum allowable deflection should not exceed 0.99 in. (25 mm). Thus, maximum stresses were significantly below the yielding strength of the steel, and deflections were within safe limits.

Summary of RRFC Bridge Performance

It has been shown through different loading situations on each bridge that providing engineered, longitudinal connections between the flatcars provided significant advantages by improving transverse load distribution. The deflection patterns for both bridges in LT2 showed that both types of longitudinal connections helped effectively distribute loads transversely across the bridge, and thus, utilizing the combined strength of all 3 flatcars to support the live load. For each bridge, the maximum stresses on the primary, longitudinal members were well below the conservative yield strength of 36 ksi (248 MPa), and the maximum deflections were comfortably less than the AASHTO requirements. Therefore, field tests have proven that RRFC bridges adequately handle Iowa legal loads for tandem trucks.

THEORETICAL ANALYSIS

A grillage model of each bridge was developed using ANSYS (Release 6.1), finite element software. Since the true boundary conditions at the supports of the bridges are unknown (i.e., actual degree of fixity, translation restraint, etc.), upper and lower bounds for the deflections and strains were established using theoretical boundary conditions that produced minimum and maximum bridge behavior/response. Results from field testing should be within the bounded deflection and strain values.

When the test truck loads from LT1 and LT2 were applied to each bridge, the results from the grillage model were in good agreement with the results obtained from the field testing, and thus, showed that stresses and deflections on these types of bridges are predictable. Figure 9 illustrates the BCB maximum theoretical and experimental midspan deflections and strains obtained during Test 2 of LT2. The dashed lines indicate the upper and lower limits for each, and the solid line represents the results obtained from field testing. The guardrail was not in place during LT2 testing, and therefore, its effects did not need to be considered in the model. Figure 10 shows the WCB maximum theoretical and experimental midspan deflections and strains Test 3 of LT2. The reason for the small discrepancy between theoretical and experimental results is due to the presence of the guardrail during this test. The flexural strength contribution of the guardrail at the edges of the bridge was unknown, and therefore, the analytical model does not compensate for it. However, the guardrail has significant strength and was in place during the testing; its effects are demonstrated by smaller deflections and strains than those predicted by the model at the edges of the bridge. Even with this small discrepancy, the theoretical and experimental results have good correspondence.

From results obtained from LT1 and LT2, it was found that the neutral axis for flexure on a flatcar can be accurately located by assuming that the three primary, longitudinal members and transverse members perform as a rigid cross-section. In an attempt to verify the grillage model results without the use of the field test results, basic flexure calculations were made for an individual flatcar while assuming a rigid cross-section, but noteworthy error was present.

CONCLUSION

Through the design, construction, field testing, and analysis of two RRFC demonstration bridges (photographs of the completed bridges are shown in Figure 11), it has been determined that RRFC bridges are a viable, economical alternative for low-volume road bridges. The success of these demonstration bridges may be directly linked to the careful selection of the RRFC, design of the longitudinal connections between flatcars, and overall design and construction practices.

The 56-ft (17.1-m), single span BCB utilized large, primary, exterior members to construct longitudinal connections in order to get composite action among the transversely placed RRFCs. Not only did these connections support their own self weight and help carry the dead load from the asphalt milling driving surface, but also deflections (and strains) were reduced by 55-60%. When examining field test results for the finished bridge, it was determined that maximum stresses were significantly less than the yielding stress of the steel, and deflections in the primary, longitudinal members were well below AASHTO limitations.

The three span, 89-ft (27.1-m) WCB required the removal of the top half of the primary, exterior member in the longitudinal connection above the deck of the RRFC. Thus, it was not possible to use a longitudinal connection similar to the LCS. Instead, a smaller connection was designed that made use of transverse timber planks to aid with transverse load distribution. By connecting the flatcars and providing transverse timber planks to help with transverse load distribution, deflections (and strains) were reduced by approximately 70%. Once again, maximum stresses were significantly less than the yielding stress of the steel, and deflections in the primary, longitudinal members were well below AASHTO limitations.

As noted previously, fatigue is not considered to be an issue since these bridges will be used on low-volume roads. Therefore, results of this research have introduced a new, efficient, and engineered county bridge replacement that will help improve low-volume road transportation.

ACKNOWLEDGEMENTS

The study presented in this paper was conducted by the Bridge Engineering Center at Iowa State University through funding provided by the Iowa Department of Transportation, Highway Division. The authors wish to thank Brian Keierleber, Buchanan County Engineer; Jim Witt, Winnebago County Engineer; and all of their personnel for their cooperation and assistance with this project. In addition, special thanks are extended to Doug Wood, ISU Research Laboratory Manager, and various ISU students for their help with the construction, instrumentation, and field testing of the demonstration bridges.

The opinions, findings, and conclusions expressed in this publication are those of the authors and not necessarily those of the Iowa Department of Transportation.

REFERENCES

1. Wipf, T.J, F.W. Klaiber, and T.L. Threadgold. *Use of Railroad Flat Cars for Low-Volume Road Bridges*. Iowa DOT Project TR-421. Iowa Department of Transportation. 1999. 141 pp.
2. Wipf, T.J, F.W. Klaiber, and J.D. Doornink. *Demonstration Project Using Railroad Flatcars for Low-Volume Bridges*. Iowa DOT Project TR-444. Iowa Department of Transportation. 2002. (in preparation).
3. *AASHTO LRFD Bridge Design Specifications, First Edition, SI Units*. American Association of State Highway and Transportation Officials (AASHTO). Washington, D.C. 1994.
4. *Standard Specifications for Highway Bridges, Sixteenth Edition*. American Association of State Highway and Transportation Officials (AASHTO). Washington, D.C. 1996.

List of Figures

Figure 1.	Typical 56-ft, V-Deck RRFC.	10
Figure 2.	Typical 89-ft RRFC.	11
Figure 3.	Buchanan County RRFC Bridge.	12
Figure 4.	Winnebago County RRFC Bridge.	13
Figure 5.	LT1 Midspan Vertical Displacements in the BCB.	14
Figure 6.	LT2 Midspan Deflections in the BCB.	15
Figure 7.	LT2 Midspan Deflections in the WCB.	16
Figure 8.	Comparison of LT1 and LT2 Midspan Deflection in the WCB.	17
Figure 9.	Theoretical and Experimental Results on the BCB.	18
Figure 10.	Theoretical and Experimental Results on the WCB.	19
Figure 11.	Completed RRFC Demonstration Bridges.	20



(a) Photograph of the 89-ft RRFC.

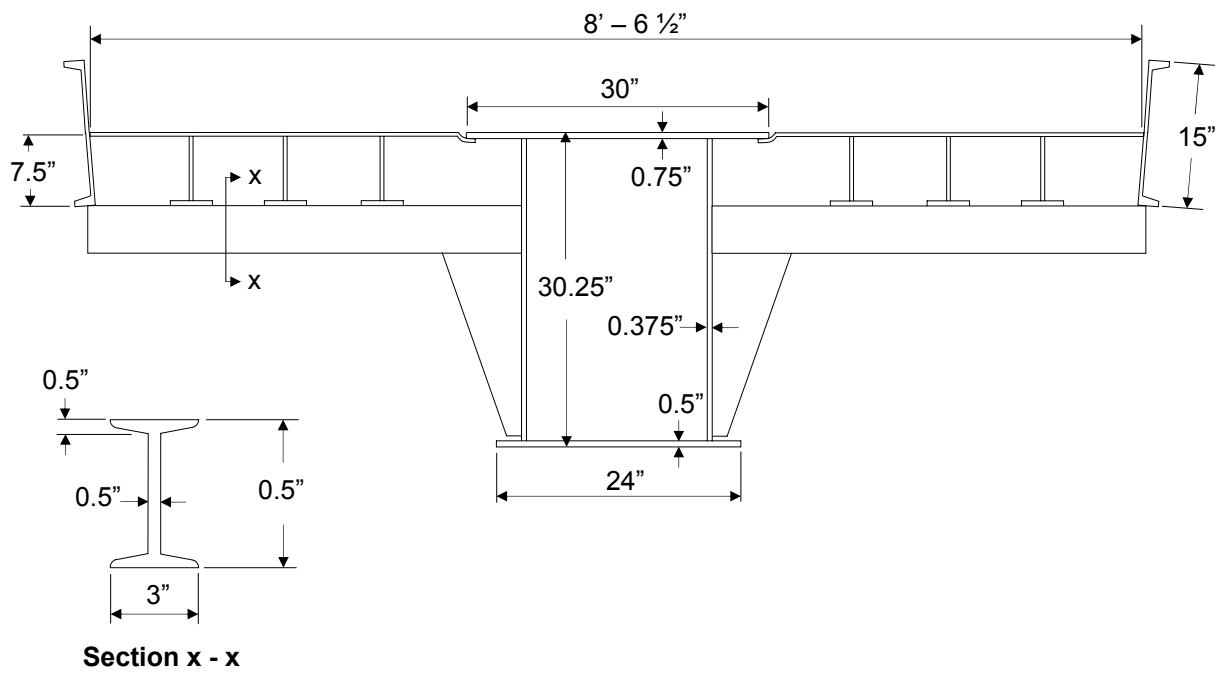

(b) Cross-Section

FIGURE 2 Typical 89-ft RRFC.

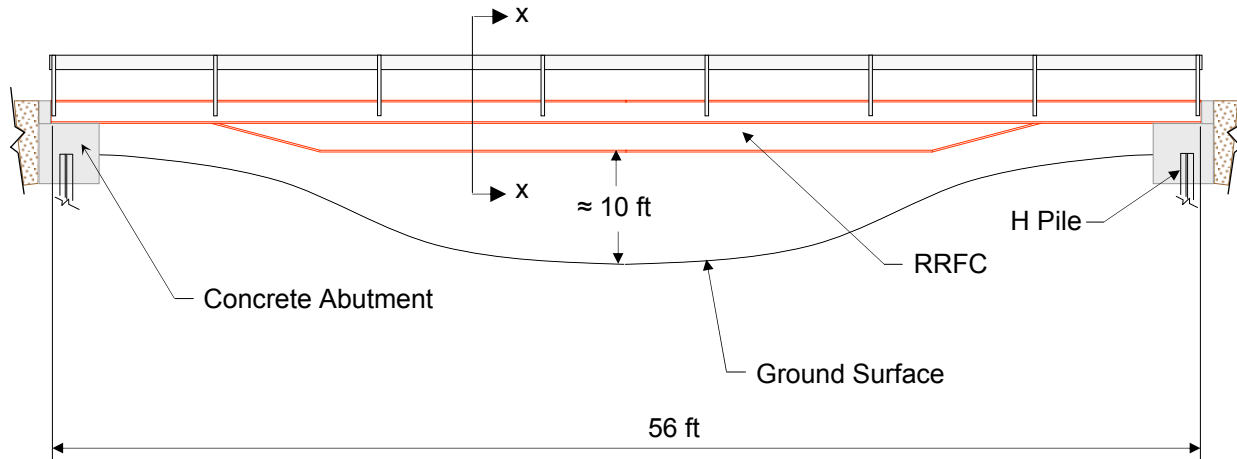

(a) Profile of BCB.

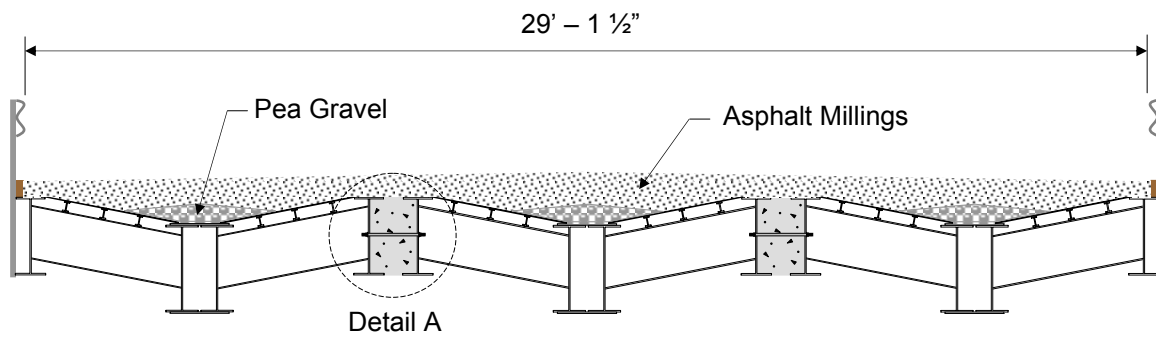

(b) Section x - x.

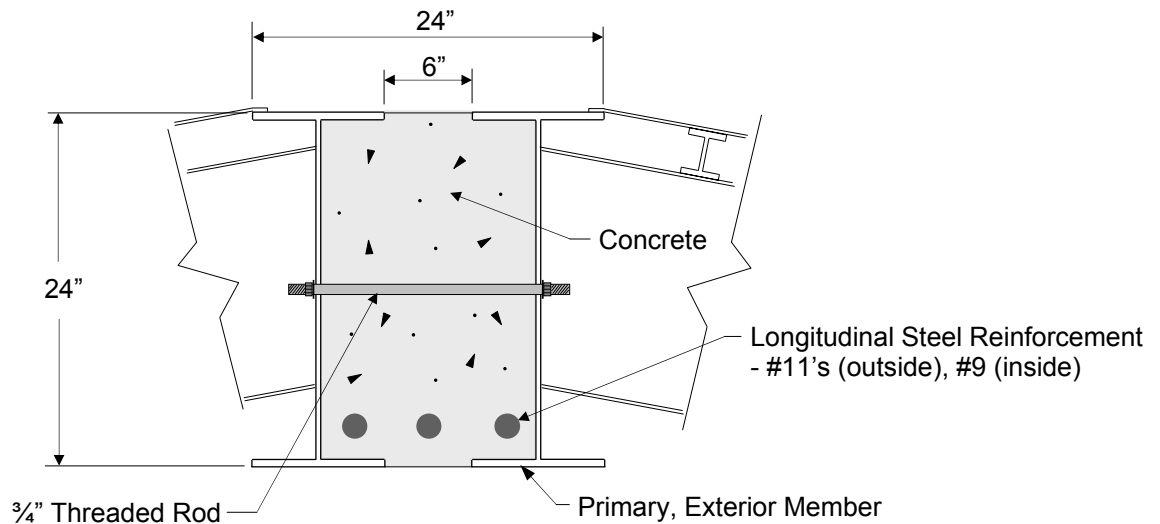

(c) Detail A.

FIGURE 3 Buchanan County RRFC Bridge.

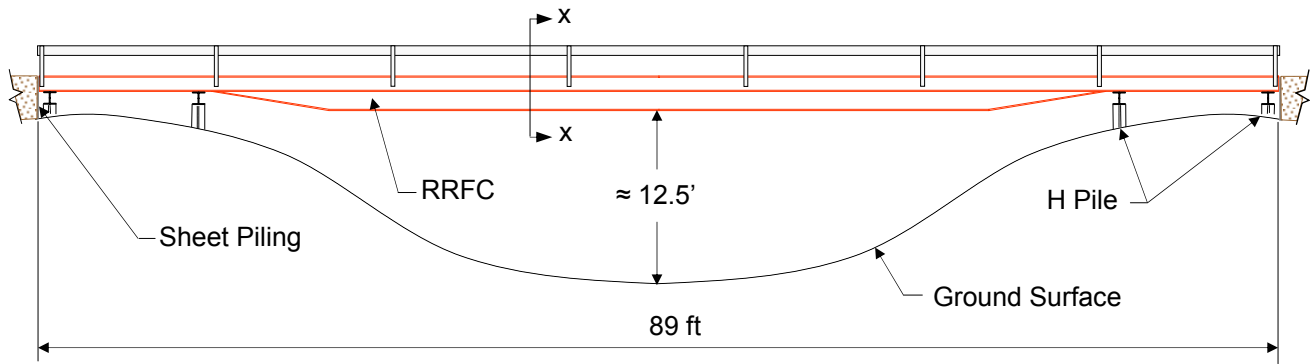

(a) Profile of WCB.

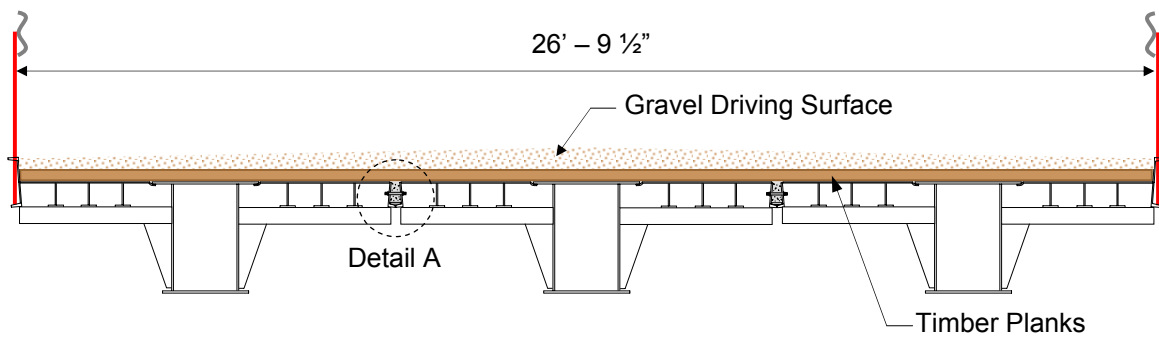

(b) Section x - x.

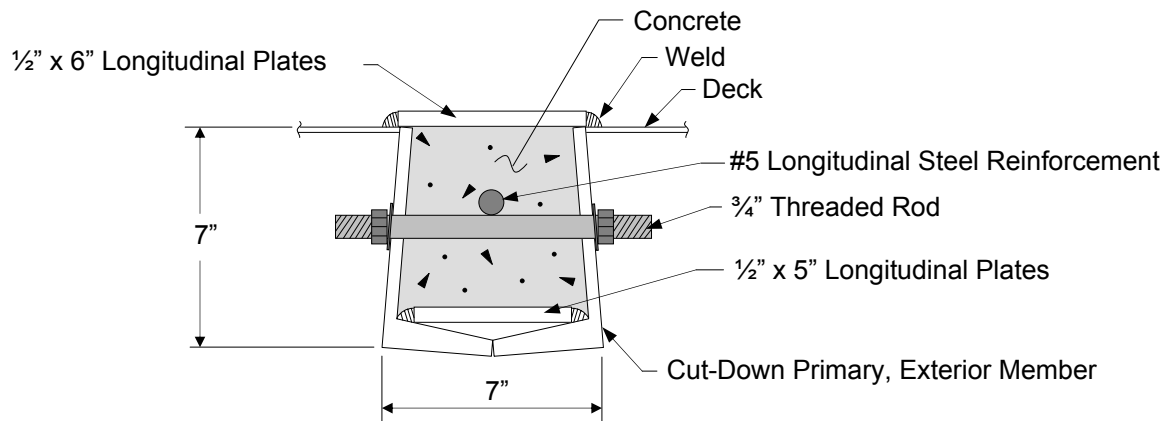

(c) Detail A.

FIGURE 4 Winnebago County RRFC Bridge.

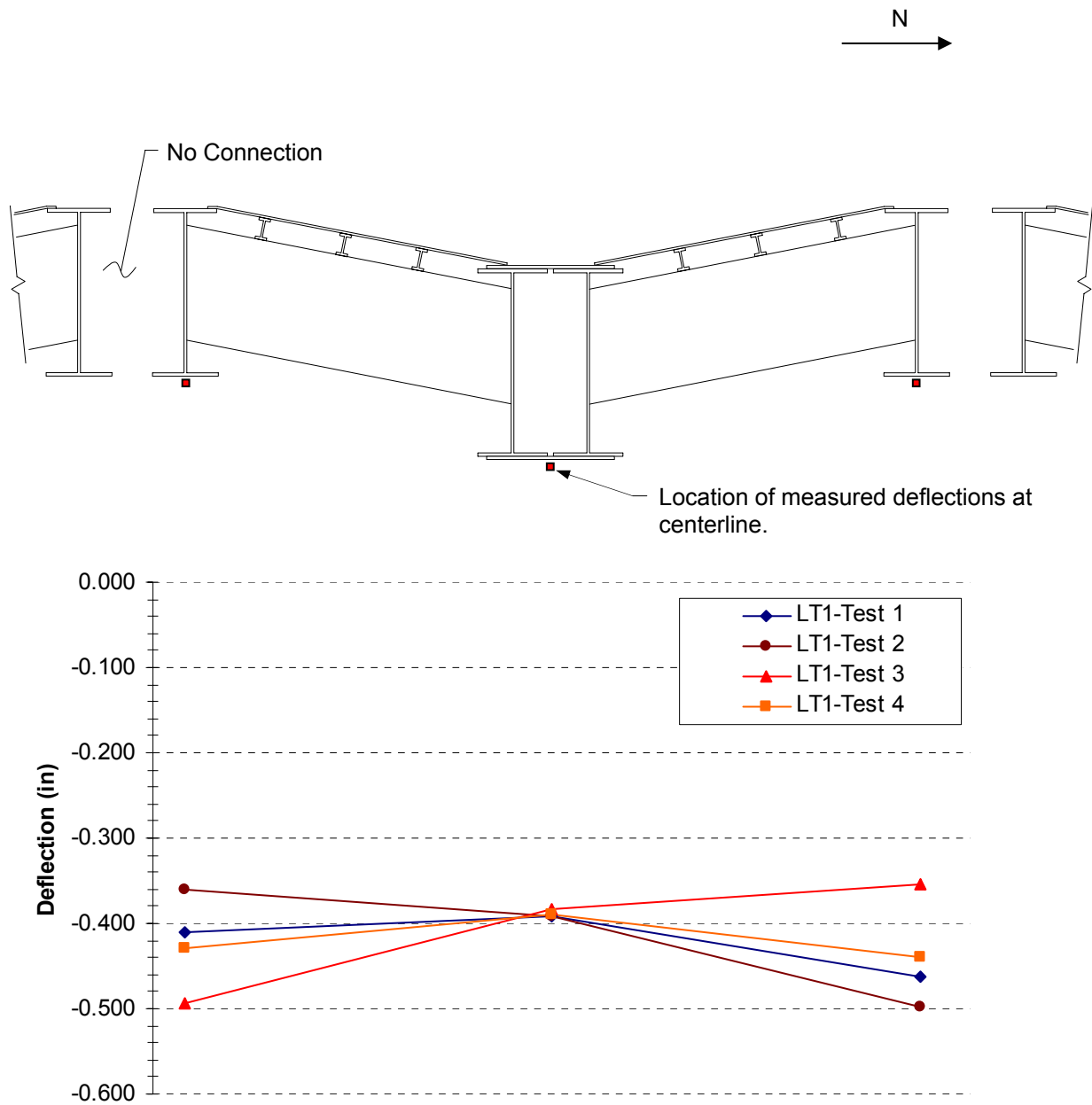
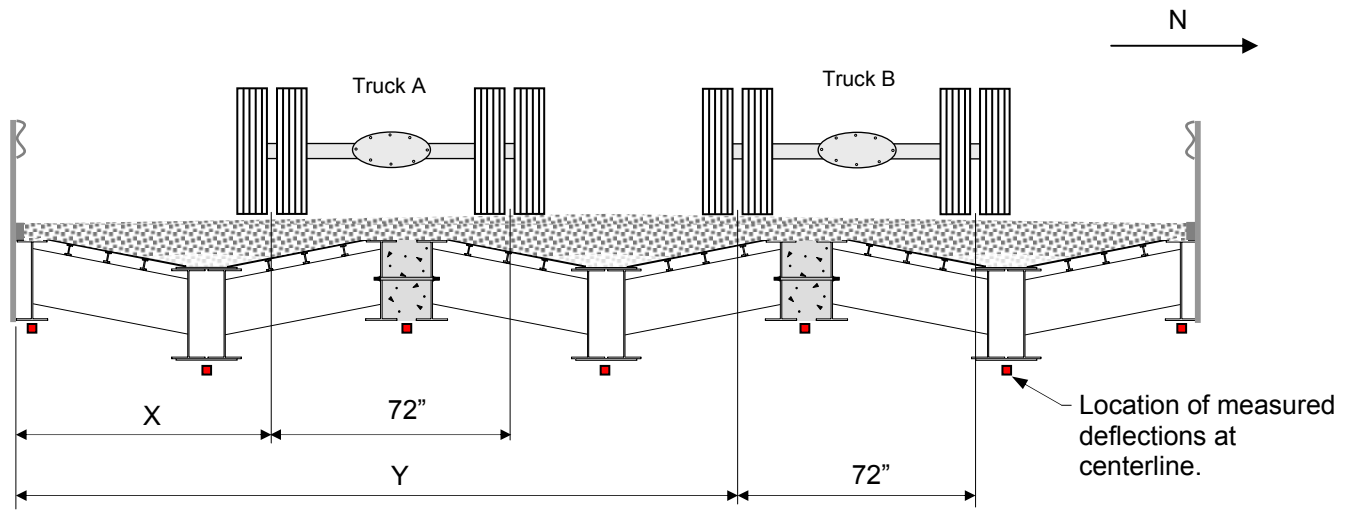

FIGURE 5 LT1 Midspan Vertical Deflection in the BCB.



LT2 Test	Transverse Position (in.)	
	Truck A	Truck B
	X	Y
1	138.75	-
2	253.50	-
3	24.00	-
4	198.00	-
5	24.00	253.00
6	67.75	209.75

Note: "-" denotes that only "Truck A" was used for the test. Variable "Y" does not apply.

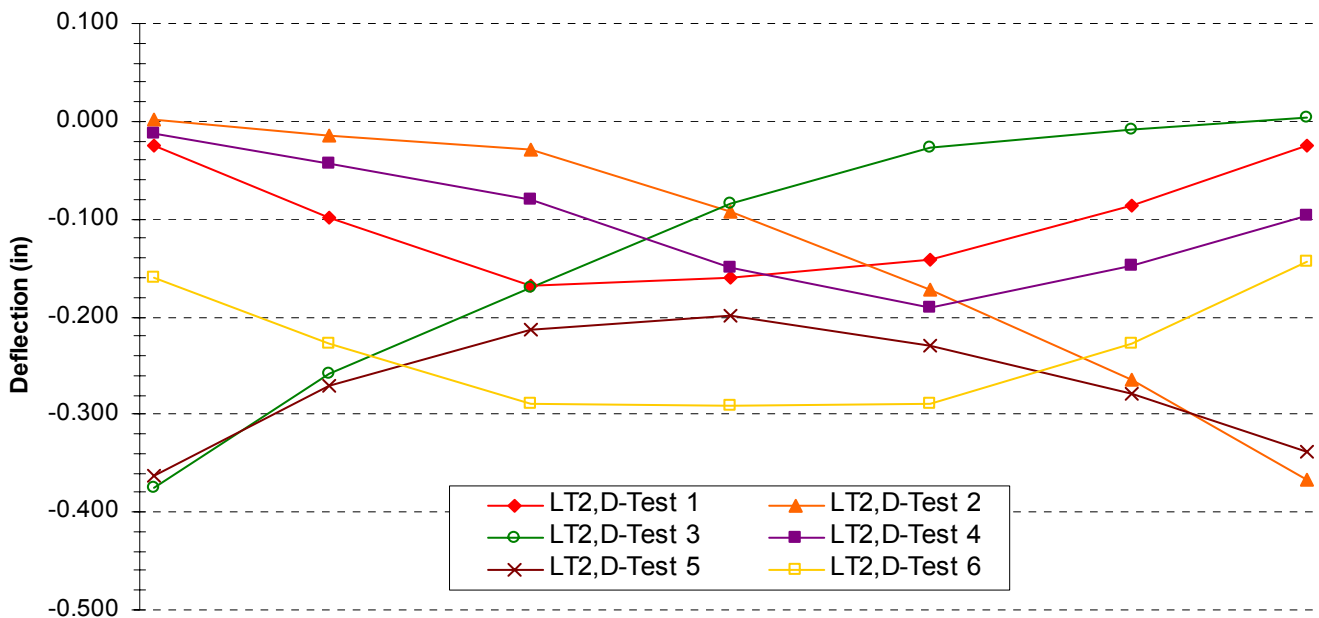
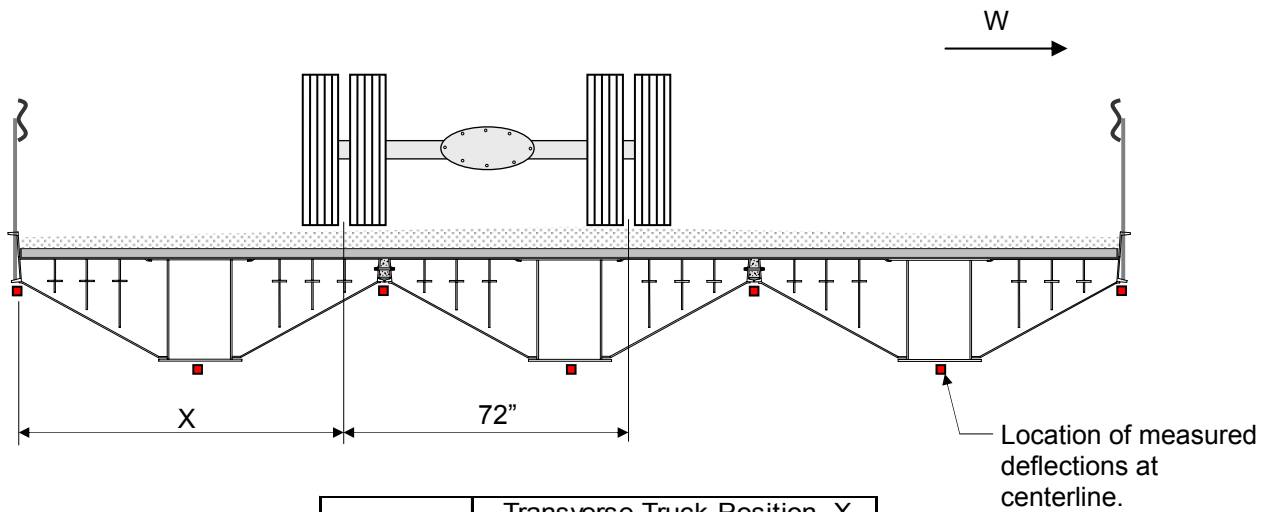

FIGURE 6 LT2 Midspan Deflections for the BCB.



LT2 Test	Transverse Truck Position, X (in)
1	24.00
2	124.75
3	297.50
4	124.75 *

* Speed = 30 mph

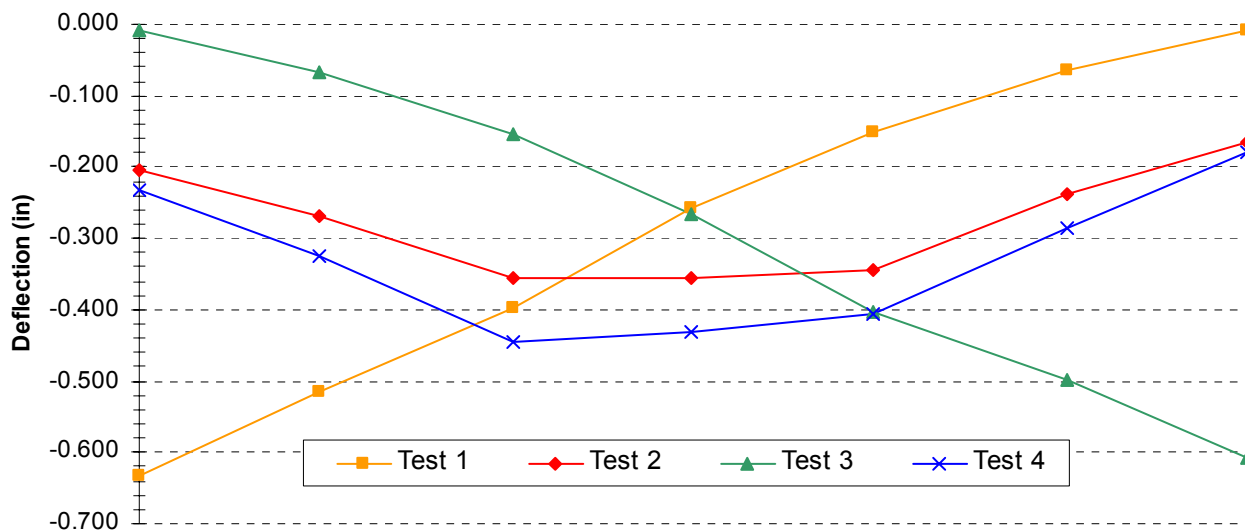
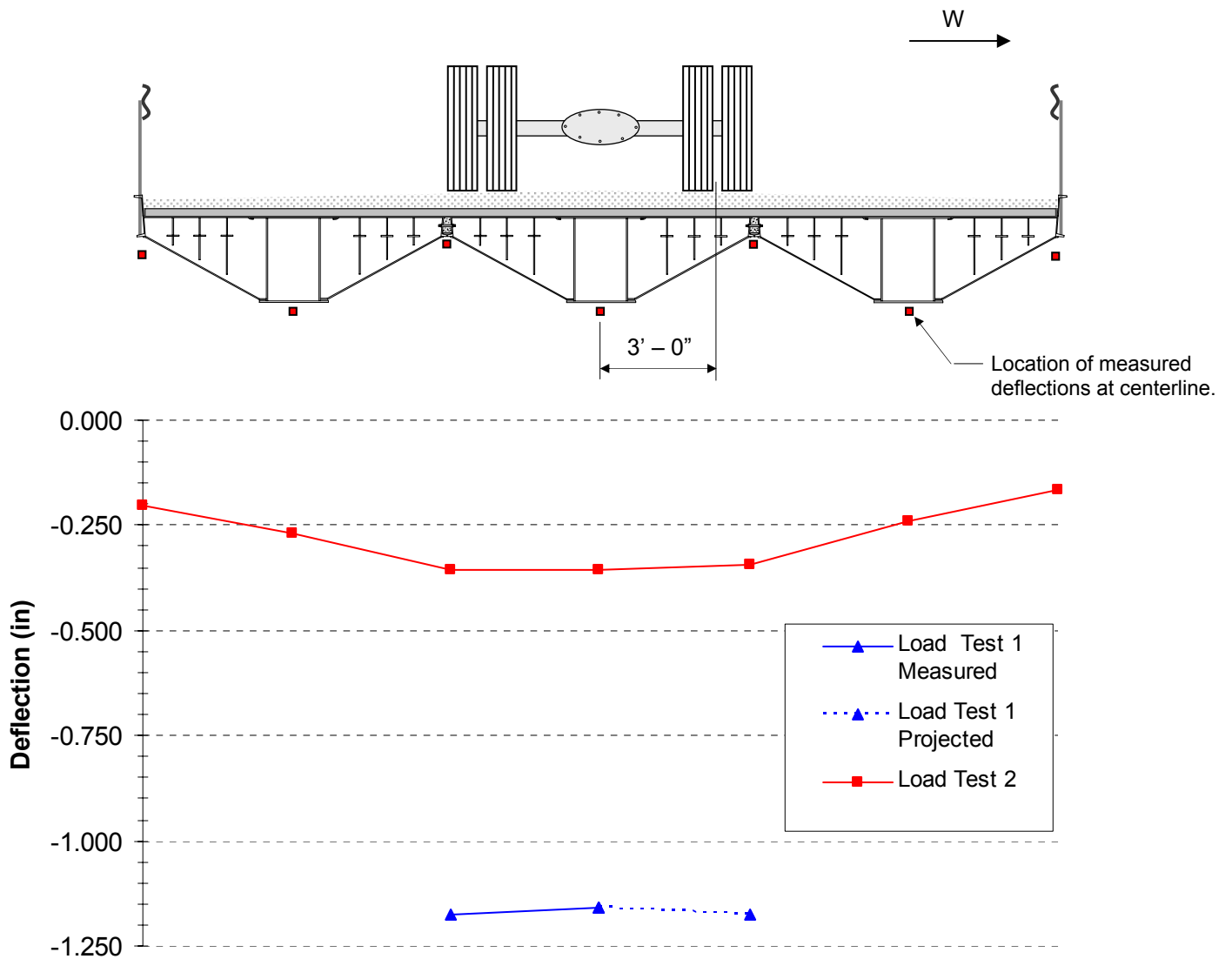

FIGURE 7 LT2 Midspan Deflections in the WCB.



Note:

- Load Test 1 performed with unconnected RRFC's
- Load Test 2 performed with connected RRFC's

FIGURE 8 Comparison of LT1 and LT2 Midspan Deflection in WCB.

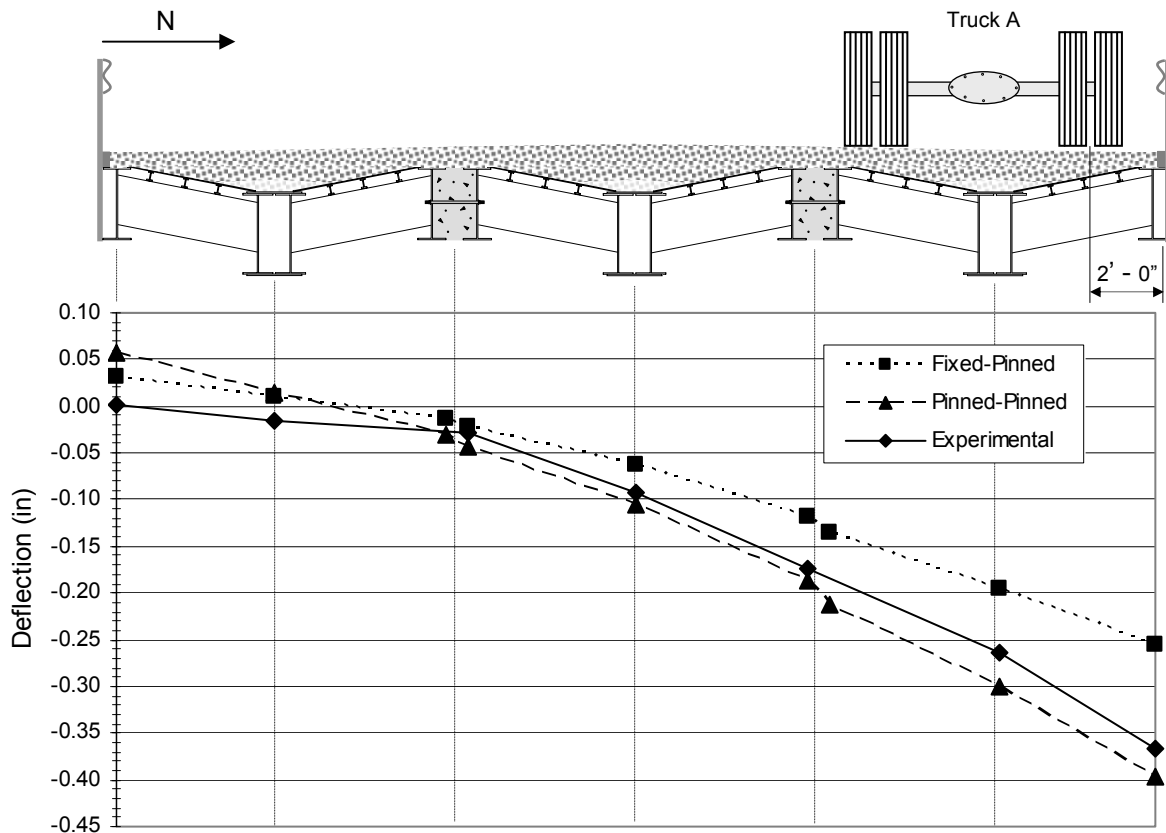

a. Deflections.

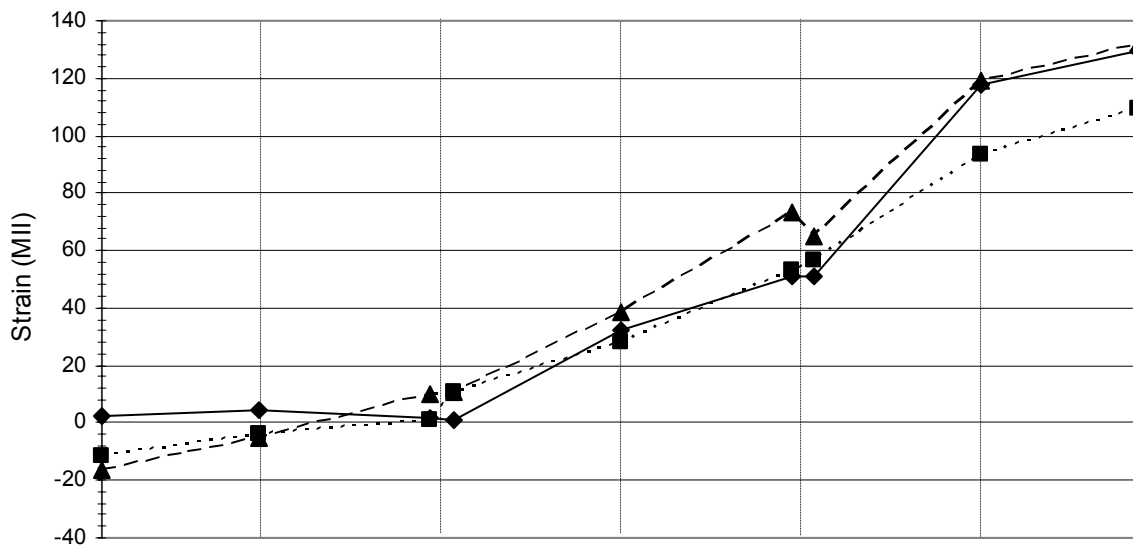

b. Member Bottom Flange Strains.

FIGURE 9 BCB Theoretical and Experimental Results for North Truck Positioning During LT2. (Upper and lower bounds represented with dashed lines)

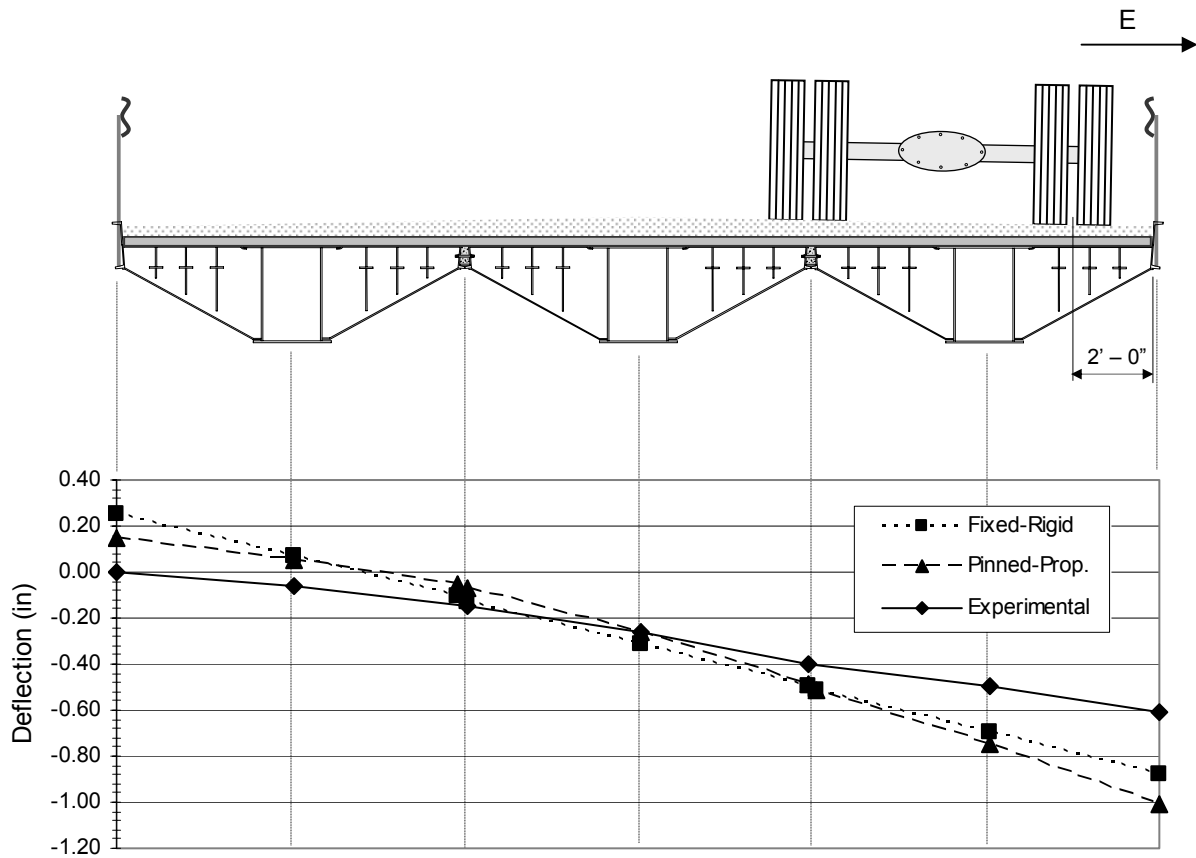

a. Deflections.

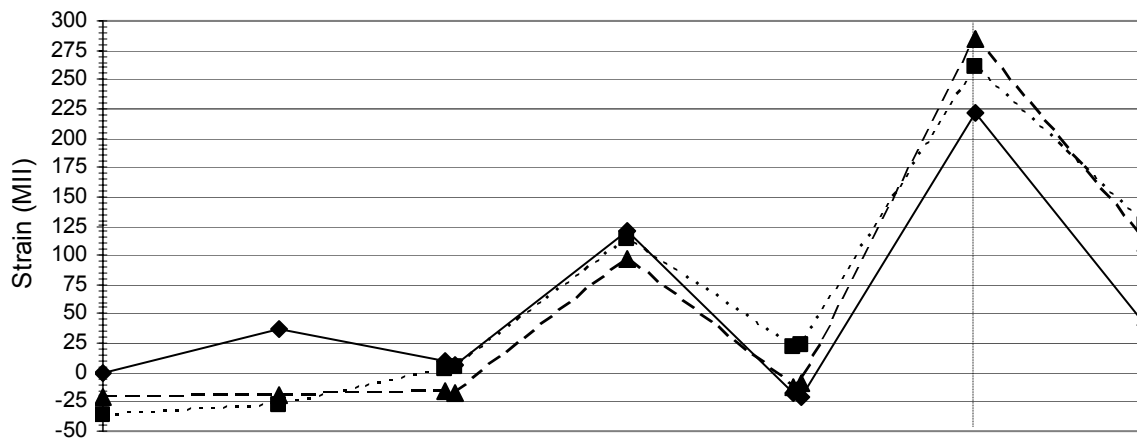

b. Member Bottom Strains.

**FIGURE 10 WCB Theoretical and Experimental Results for East Truck Positioning During LT2.
 (Upper and lower bounds represented with dashed lines)**



(a) Photograph of BCB.



(b) Photograph of WCB.

FIGURE 11 Completed RRFC Demonstration Bridges.