2D-1 General Information for BMPs

A. Description and performance of stormwater BMPs

A stormwater best management practice (BMP) is a technique, measure, or structural control that is used for a given set of conditions to manage the quantity and improve the quality of stormwater runoff in the most cost-effective manner. BMPs can be either:

1. **Non-structural BMPs.** Include a range of pollution prevention, education, or institutional management and development practices designed to limit the conversion of rainfall to runoff and to prevent pollutants from entering runoff at the source of runoff generation.
2. **Structural BMPs.** Engineered and constructed systems that are used to treat the stormwater at either the point of generation or the point of discharge to either the storm sewer system or to receiving waters (e.g. detention ponds or constructed wetlands).

No single BMP can address all stormwater problems. Each type has certain limitations based on drainage area served, available land space, cost, and pollutant removal efficiency; as well as a variety of site-specific factors such as soil types, slopes, depth of groundwater table, etc. Careful consideration of these factors is necessary in order to select the appropriate BMP(s) for a particular location. Regardless of the type, stormwater BMPs will be most effective when implemented as part of a comprehensive stormwater management program that includes proper selection, design, construction, inspection, and maintenance. Descriptions of commonly-used BMPs, along with important factors for design, advantages, disadvantages, and maintenance considerations for each BMP can be found in Part 2D.

B. Goals of stormwater BMPs

In existing urbanized areas, BMPs can be implemented to address a range of water quantity and water quality considerations. The applicability of individual practices will vary depending on the needs of the practitioner. For new urban development, BMPs should be designed and implemented so that the post-development peak discharge rate, volume, and pollutant loadings to receiving waters are as close as possible to pre-development values. In some instances, the application of BMPs can improve water quality and or reduce runoff volume when the watershed had been altered from its natural condition. In order to meet these goals, BMPs are typically implemented to address three factors:

1. Flow rate control (peak flow reduction)
2. Reduction of runoff volume from urbanizing areas
3. Pollutant removal and pollutant source reductions

Properly designed, constructed, and maintained structural BMPs can effectively remove a wide range of pollutants from urban runoff. Pollutant removal in stormwater BMPs can be accomplished through a number of physical and biochemical processes. The efficiency of a given BMP in removing pollutants is dependent upon a number of site-specific variables, including the size, type, and design of the BMP; the soil types and characteristics; the geology and topography of the site; the intensity and duration of the rainfall; the length of antecedent dry periods; climate factors such as temperature,

solar radiation, and wind; the size and characteristics of the contributing watershed; and the properties and characteristics of the various pollutants.

C. Pollutant removal processes

Removal of pollutants from urban runoff can occur through the following mechanisms:

1. **Sedimentation.** Sedimentation is the removal of suspended particulates from the water column by gravitational settling. The settling of discrete particles is dependent upon the particle velocity, the fluid density, the fluid viscosity, and the particle diameter and shape. Sedimentation can be a major mechanism of pollutant removal in BMPs such as ponds and constructed wetlands, and can remove a variety of pollutants from stormwater runoff. Pollutants such as metals, hydrocarbons, nutrients, and oxygen-demanding substances can become adsorbed or attached to particulate matter, particularly clay soils. Removal of these particulates by sedimentation can therefore result in the removal of a large portion of these associated pollutants.

The main factor governing the efficiency of a BMP at removing suspended matter by sedimentation is the time available for particles to undergo settling. Particle size directly affects the pollutant settling ability: the smaller the particle size, the longer it takes to settle. Conversely, the larger the particle, the faster its settling velocity is. Fine particulates such as clay and silt can require detention times of days or even weeks to settle out of suspension. Therefore, it is important to evaluate the settling characteristics of the particulates in runoff before BMP design in order to determine the detention time necessary for adequate settling to occur.

The overall efficiency of a BMP in removing particulates by settling is also dependent upon the initial concentration of suspended solids in the runoff. In general, when runoff contains higher initial concentrations of suspended solids, the BMP will achieve greater removal efficiency. In addition, some particles, such as fine clays, will not settle out of suspension without the aid of a coagulant. As a result, there is usually a minimum practical limit of approximately 10 mg/l of TSS (total suspended sediment), below which additional TSS removal cannot be expected to occur (UDFCD, 1992). Turbulence, eddies, circulation currents, and diffusion at inlets and outlets affect the settling ability of particles. Each of these factors can move particles back up into the water column. In general, the larger the stormwater loading rate, the lower the removal of sediment by settling. Settling will also take place after stormwater is trapped and ponded between storms. Because the time interval between storm events is variable, understanding the effective ratio of storage volume to mean runoff rate and the ratio of sediment volume removed to mean runoff rate is essential to predicting long-term averages.

2. **Flotation.** Flotation is the separation of particulates with a specific gravity less than that of water. Trash such as paper, plastics, and other low-density materials can be removed from stormwater by flotation. If the inlet area of a BMP is designed to allow for the accumulation of floatable materials, then these accumulated materials can periodically be manually removed from the BMP. Significant amounts of floatables can be removed from stormwater in properly-designed BMPs in this manner. In addition, oils and hydrocarbons will frequently rise to the surface in stormwater BMPs. If the BMP is designed with an area for these materials to accumulate, then significant removals of these pollutants can occur. Many modular or drop-in filtration systems incorporate an oil and grease or hydrocarbon trap with a submerged outlet pipe that allows these contaminants to accumulate for periodic removal.
3. **Filtration.** Filtration is the removal of particulates from water by passing the water through a porous media. Media commonly used in stormwater BMPs include soil, sand, gravel, peat, compost, and various combinations such as peat/sand, soil/sand and sand/gravel. Filtration is a complex process dependent on a number of variables. These include the particle shape and size,

the size of the voids in the filter media, and the velocity at which the fluid moves through the media. Filtration can be used to remove solids and attached pollutants such as metals and nutrients. Organic filtration media such as peat or leaf compost can also be effective at removing soluble nutrients from urban runoff.

4. **Infiltration.** Infiltration is the most effective means of controlling stormwater runoff since it reduces the volume of runoff that is discharged to receiving waters *and* the associated water quality impacts that runoff can cause. Infiltration is also an important mechanism for pollutant control. As runoff infiltrates into the ground, particulates and attached contaminants such as metals and nutrients are removed by filtration, and dissolved constituents can be removed by adsorption. However, infiltration is not appropriate in all areas.
5. **Adsorption.** Adsorption, while not a common mechanism used in stormwater BMPs, can occur in infiltration systems where the underlying soils contain appreciable amounts of clay. The clay and organic particles in soil hold negative charges. The ability of soil and organic matter to hold cations, such as phosphorus and aluminum, represent the soil's cation exchange capacity. This process is most readily used to remove soluble pollutants from stormwater. Dissolved metals that are contained in stormwater runoff can be bound to the clay particles as stormwater runoff percolates through clay soils in infiltration systems. Organic matter, such as peat or leaf matter in the filter media, can remove pollutants using the cation exchange capacity of the media. The treatment of runoff with media filters, such as the bioretention cell (Clar and Green, 1993), is an example of a cation exchange process combined with filtration. A shallow basin collects the runoff and gradually discharges through a filter media filled with planting soil, peat, or composted leaf media. The filter media traps particulates (through filtration) and adsorbs organic chemicals, removing up to 90% of solids, 85% of oil and grease, and 82-98% of heavy metals (through cation exchange from leaf decomposition) in stormwater that passes through the filter.
6. **Biological uptake.** Biological uptake of nutrients is an important mechanism of nutrient control in stormwater BMPs. Urban runoff typically contains significant concentrations of nutrients. Ponds and wetlands can be useful for removing these nutrients through biological uptake. This occurs as aquatic plants, algae, microorganisms and phytoplankton utilize these nutrients for growth. Periodic harvesting of vegetation in BMPs allows for permanent removal of these nutrients. If plants are not harvested, however, nutrients can be re-released to the water column from plant tissue after the plants die.
7. **Biological conversion.** Organic contaminants can be broken down by the action of aquatic microorganisms in stormwater BMPs. Bacteria present in BMPs can degrade complex and/or toxic organic compounds into less harmful compounds that can reduce the toxicity of runoff to aquatic biota.
8. **Degradation.** BMPs such as ponds and wetlands can provide the conditions necessary for the degradation of certain organic compounds, including certain pesticides and herbicides. Open pool BMPs can provide the necessary conditions for volatilization, hydrolysis, and photolysis of a variety of organic compounds to take place.

2D-2 Non-Structural Controls

A. Education, recycling, and source controls

Public education can be an effective means of reducing the amounts of non-point source pollutants entering receiving streams. The public is often unaware that the combined effects of their actions can cause significant non-point source pollution problems. Proper education on day-to-day activities such as recycling of used automotive fluids, household chemical and fertilizer use, animal waste control, and other activities can significantly reduce non-point source pollutant loadings to urban streams. The main components of a public education program include:

- Automotive product disposal
- Commercial and retail space good housekeeping
- General community outreach
- Industrial good housekeeping
- Storm drain inlet stenciling
- Pesticide/herbicide use
- Fertilizer use
- Household hazardous material disposal
- Lawn debris management
- Pet waste disposal
- Illicit discharge detection and elimination

B. Maintenance practices

Maintenance programs are important in order to reduce the pollutant contribution from the urban landscape and to ensure that stormwater collection and treatment systems are operating as designed. Major maintenance practices that can be used include:

- Catch basin cleaning
- Street and parking lot sweeping
- Road and ditch maintenance
- Limited road salting and sanding
- Sediment and floatable removal from BMPs
- Vegetation maintenance
- General BMP maintenance

Additional information on non-structural BMPs can be found at:
<http://www.epa.gov/npdes/stormwater/menuofbmps>.

2D-3 Structural Controls

A. Structural BMPs

Structural BMPs include engineered and constructed systems that are designed to provide control for water quantity and/or water quality of stormwater runoff. Structural BMPs can be grouped into several general categories. However, the distinction between BMP types and the terminology used to group structural BMPs is an area that needs standardization. In particular, the terms “retention” and “detention” are sometimes used interchangeably, although they do have distinct meanings. Stormwater detention is usually defined as providing temporary storage of a runoff volume for subsequent release (WEF/ASCE, 1992). Examples include detention basins, underground vaults, tanks or pipes, and deep tunnels, as well as temporary detention in parking lots, roof-tops, depressed grassy areas, etc. Retention is generally defined as providing storage of stormwater runoff without subsequent surface discharge (WEF/ASCE, 1992). With the strict interpretation of this definition, retention practices would be limited to those practices that either infiltrate or evaporate runoff, such as infiltration trenches and basins. However, retention is also commonly used to describe practices that retain a runoff volume (and hence have a permanent pool) until it is displaced in part or in total by the runoff event from the next storm. Examples include retention ponds, tanks, tunnels, and underground vaults or pipes, and wetland basins. For purposes of this document, and to be consistent with the definitions and terminology used in the ASCE National Stormwater BMP Database, structural BMPs have been grouped and defined as follows:

1. **Infiltration systems** capture a volume of runoff and infiltrate it into the ground.
2. **Detention systems** capture a volume of runoff and temporarily detain (withhold) that volume for subsequent release. Traditional detention systems do not retain a significant permanent pool of water between runoff events. Detention systems do not reduce the total volume of surface runoff from a storm event since the entire captured volume is eventually released after the period of detention. The main goal of traditional detention systems is to reduce the peak discharge rate to the downstream conveyance. A variant of the traditional dry detention basin is designed as an “extended dry detention pond” providing 24-48 hours of holding time for the runoff from the water quality design storm.
3. **Wet-detention systems** (stormwater ponds) capture a volume of runoff and retain that volume until it is displaced in part or in total by the next runoff event. These systems are better defined as “extended detention” or “wet pond” systems since the runoff volume is eventually released to the downstream conveyance after an extended period of storage (usually 24-48 hours). A true retention system would *permanently* retain all or part of the captured runoff volume and prevent its release to the downstream conveyance. The retained volume is either lost to evaporation, infiltrated into the soil profile and then to the water table, or is subsequently withdrawn for consumptive non-potable re-use. These systems typically maintain a significant permanent pool volume of water between runoff events.
4. **Constructed wetland systems** (stormwater wetlands) are similar to detention systems, except that a major portion of the BMP water surface area (in pond systems) or bottom (in shallow marsh-type systems) contains wetland vegetation. This group also includes wetland channels.

5. **Filtration systems** use some combination of a granular filtration media such as sand, soil, organic material, carbon, or a membrane to remove constituents found in runoff.
6. **Vegetated systems (biofilters)** such as swales and filter strips are designed to convey and treat either shallow flow (swales) or sheet flow (filter strips) runoff.
7. **Minimizing directly connected impervious areas (DCIA)** describes a variety of practices that can be used to reduce the amount of surface area directly connected to the storm drainage system by minimizing or eliminating traditional curb and gutter. This is considered by some to be a non-structural practice, but it has been included under the structural heading due to the need to design and construct alternative conveyance and treatment options.
8. **Miscellaneous and vendor-supplied systems** include a variety of proprietary and miscellaneous systems that do not fit under any of the above categories. These include catch basin inserts, hydrodynamic devices, and filtration devices.

In terms of the unified stormwater sizing criteria (Part 2B), a structural stormwater control, or set of structural controls, must:

- Retain and treat the water quality volume, WQ_v (the runoff generated by first 1.25 inches of rainfall).
- Meet recharge volume requirements, Rev. The intent of the recharge criteria is to maintain existing groundwater recharge rates at development sites. This helps to preserve existing water table elevations, thereby maintaining the hydrology of streams and wetlands during dry weather. The volume of recharge that occurs on a site depends on slope, soil type, vegetative cover, precipitation, and evapotranspiration. This will be variable depending on the site soils and is considered part of the WQ_v .
- Control the channel protection volume, CP_v (24 hours of extended detention for the 1-year, 24-hour rainfall event), where necessary or required.
- Control for overbank flood protection, Q_{p5} (detention for control of the post-development 2-yr and 5-year, 24-hour storm peak discharge rate to the pre-development rate; control of the post-development peak rates for major storms – 25-yr through the 50-yr – may also be required by local jurisdictions).
- Provide for extreme flood protection, Q_f by either (1) control of the peak discharge increase from the 100-year storm event, Q_f , through detention; or (2) safely pass Q_f through the structural control and allow it to discharge into a receiving water whose protected floodplain is sufficiently sized to account for extreme flow increases without causing damage.

B. Structural control categories

The structural stormwater control practices recommended in this section have been placed into one of two categories based upon their applicability and ability to meet stormwater management goals:

1. **General application structural controls.** General application structural controls are recommended for use with a wide variety of land uses and development types. These structural controls have a demonstrated ability to effectively treat the WQ_v , and are presumed to be able to remove 80% of the annual average TSS load in typical post-development urban runoff when designed, constructed, and maintained in accordance with recommended specifications. Several of the general application structural controls can also be designed to provide water quantity control, i.e. downstream channel protection (CP_v), over-bank flood protection (Q_p) and/or extreme flood protection (Q_f). General application controls are the recommended stormwater

management facilities for a site wherever feasible and practical. A detailed discussion of each of the general application controls, as well as design criteria and procedures can be found in subsequent sections of this manual. A summary of the recommended general application controls is listed in Table 2.

2. **Limited application controls.** Limited application structural controls are recommended only for limited use for specific site or design conditions. Generally, these practices:

- Cannot individually achieve the 80% TSS removal target
- Are intended to address hotspot or specific land use constraints or conditions
- May have high or special maintenance requirements that may preclude their use

These structural controls are recommended for use with particular land uses and densities, for limited usage on larger projects, or can be used as a pretreatment measure or in series with other structural controls to meet pollutant removal goals. Limited application controls are typically used for water quality treatment only. Limited application structural controls should be considered primarily for commercial, industrial, or institutional developments. A detailed discussion of each of the limited application controls, as well as design criteria and procedures can be found in subsequent sections of this manual. Table 3 lists the limited application structural stormwater control practices, along with the rationale for limited use.

3. **Conventional detention structural controls.** Table 4 lists the conventional detention structural stormwater control practices that have been used in Iowa for many years. These structural controls are recommended only for providing water quantity control, i.e. channel protection, overbank flood protection, and/or extreme flood protection in a stormwater treatment train. A detailed discussion of detention practices, as well as design criteria and procedures can be found in Part 2G. Due to the potential for pollutant re-suspension and outlet clogging, conventional detention structural controls are not intended to treat stormwater runoff, and should be used downstream of other water quality structural controls in a treatment train configuration or for downstream regional detention for peak discharge control for major storm events (>25-yr RI).

Table 1: Treatment removal processes occurring in structural BMPs

Pollutant	Removal Process and BMP Types				
	Ponds	Wetlands	Infiltration	Biofilter	Sand Filter
Solids	Settling	Adsorption Settling	Adsorption Filtration	Adsorption Filtration Settling	Filtration
Nutrients	Biological uptake	Biological uptake	Adsorption	Adsorption Biological uptake	Adsorption
Heavy metals	Adsorption Settling	Adsorption Settling Biological uptake	Adsorption Filtration	Adsorption Filtration Settling Biological uptake	Adsorption Filtration
Toxic organics	Adsorption Degradation Biological conversion	Adsorption Degradation Biological conversion	Adsorption	Adsorption Filtration Biological conversion	Adsorption Filtration
Oil and grease	Adsorption Settling	Adsorption Settling	Adsorption	Adsorption Settling	Adsorption
Biochemical Oxygen Demand	Biological conversion	Biological conversion	Biological conversion	Biological conversion	Biological conversion
Bacteriological	Settling UV (sunlight) Predation	Settling UV (sunlight) Predation	Filtration	Filtration Settling	Filtration

Table 2: General application structural controls

Structural Control	Description and Rationale for Use
<p><i>Infiltration</i></p> <ul style="list-style-type: none"> • Infiltration trench • Infiltration basins 	<p><i>Infiltration trench:</i> An excavated trench filled with stone aggregate, used to capture and allow infiltration of stormwater runoff into the surrounding soils from the bottom and sides of the trench.</p> <p><i>Infiltration basins:</i> Shallow detention basins constructed over permeable soils. Suspended solids are removed through sedimentation and the detained runoff is allowed to infiltrate through the bottom of the basin.</p>
<p><i>Enhanced Swales</i></p> <ul style="list-style-type: none"> • Dry swale • Wet swale/wetland channel 	<p>Enhanced swales are vegetated open channels that are explicitly designed and constructed to capture and treat stormwater runoff within dry or wet cells formed by check dams or other means.</p>
<p><i>Bioretention</i></p> <ul style="list-style-type: none"> • Bioretention area • Rain gardens 	<p>Bioretention areas are shallow stormwater basins or landscaped areas that utilize engineered soils and vegetation to capture and treat stormwater runoff. Runoff may be returned to the conveyance system, or allowed to partially or fully infiltrate into the soil.</p>
<p><i>Sand Filters</i></p> <ul style="list-style-type: none"> • Surface sand filter • Perimeter sand filter 	<p>Sand filters are multi-chamber structures designed to treat stormwater runoff through filtration, using a sand bed as its primary filter media. Filtered runoff may be returned to the conveyance system, or allowed to partially or fully infiltrate into the soil.</p>
<p><i>Stormwater Ponds</i></p> <ul style="list-style-type: none"> • Wet pond • Wet extended detention pond • Micro-pool extended detention pond • Multiple pond systems 	<p>Stormwater ponds are constructed stormwater retention basins that have a permanent pool (or micropool) of water. Runoff from each rain event is detained and treated in the pool.</p>
<p><i>Stormwater Wetlands</i></p> <ul style="list-style-type: none"> • Shallow wetland • Extended detention shallow wetland • Pond/wetland systems • Pocket wetland 	<p>Stormwater wetlands are constructed wetland systems used for stormwater management. Stormwater wetlands consist of a combination of shallow marsh areas, open water, and semi-wet areas above the permanent water surface.</p>

Table 3: Limited application structural controls

Structural Control	Description and Rationale for Limited Use
<p><i>Vegetative practices</i></p> <ul style="list-style-type: none"> • Filter strip • Grass channel 	<p>Both filter strips and grass channels provide biofiltering of stormwater runoff as it flows across the grass surface. However, by themselves, these controls cannot meet the 80% TSS removal performance goal. Consequently, both filter strips and grass channels should only be used as pretreatment measure or as part of a treatment train approach.</p>
<p><i>Filtering practices</i></p> <ul style="list-style-type: none"> • Organic filter • Underground sand filter 	<p><i>Organic filters:</i> Organic filters are surface sand filters where organic materials such as a leaf compost or peat/sand mixture are used as the filter media. These media may be able to provide enhanced removal of some contaminants, such as heavy metals. Given their potentially high maintenance requirements, they should only be used in environments that warrant their use.</p> <p><i>Underground sand filters:</i> Underground sand filters are systems located in an underground vault. These systems should only be considered for extremely high-density or space-limited sites.</p>
<p><i>Wetland systems</i></p> <ul style="list-style-type: none"> • Submerged gravel wetlands 	<p>Submerged gravel wetlands systems use wetland plants in submerged gravel or crushed rock media to remove stormwater pollutants. These systems should only be used in mid- to high-density environments where the use of other structural controls may be precluded. The long-term maintenance burden of these systems is uncertain.</p>
<p><i>Pavement systems</i></p> <ul style="list-style-type: none"> • Portland cement pervious concrete • Porous asphalt concrete • Modular porous paver systems 	<p>Porous pavements are permeable pavement surfaces with an underlying stone reservoir to temporarily store surface runoff before it infiltrates into the subsoil.</p> <p><i>Portland cement pervious concrete</i> is the term for a mixture of coarse aggregate, Portland cement, and water that allows for rapid infiltration of water.</p> <p><i>Modular porous paver systems</i> consist of open void paver units laid on a gravel subgrade. Pervious concrete, porous asphalt, and porous paver systems provide water quality and quantity benefits, but have high workmanship and maintenance requirements. They have a high failure rate if off-site sediment loads are not controlled.</p>

Table 4: Conventional detention structural controls

Structural Control	Description
<p>Dry detention/dry extended detention basins</p>	<p>Dry detention basins and dry extended detention (ED) basins are surface facilities intended to provide for the temporary storage of stormwater runoff to reduce downstream water quantity impacts (peak discharge control).</p>
<p>Multi-purpose detention areas</p>	<p>Multi-purpose detention areas are site areas used for one or more specific activities, such as parking lots and rooftops, and are also designed for the temporary storage of runoff.</p>
<p>Underground detention</p>	<p>Underground detention tanks and vaults are an alternative to surface dry detention for space-limited areas where there is not adequate land for a dry detention basin or multi-purpose detention area.</p>

C. Structural stormwater control pollutant removal capabilities

General and limited application structural stormwater controls are intended to provide water quality treatment for stormwater runoff. Though each of these structural controls provides pollutant removal capabilities, the relative capabilities vary between structural control practices and for different pollutant types. Pollutant removal capabilities for a given structural stormwater control practice are based on a number of factors, including the physical, chemical, and/or biological processes that take place in the structural control and the design and sizing of the facility. In addition, pollutant removal efficiencies for the same structural control type and facility design can vary widely depending on the tributary land use and area, incoming pollutant concentration, rainfall pattern, time of year, maintenance frequency and numerous other factors.

To assist the designer in evaluating the relative pollutant removal performance of the various structural control options, Tables 5 and 6 provide nominal design removal efficiencies for each of the general and limited application control practices. It should be noted that these values are *conservative* average pollutant reduction percentages for design purposes derived from sampling data, modeling, and professional judgment. A structural control design may be capable of exceeding these performances, however the values in the table are minimum reasonable values that can likely be achieved when the structural control is sized, designed, constructed, and maintained in accordance with the recommended design criteria and specifications included in this manual. Where the pollutant removal capabilities of an individual structural stormwater control are not deemed sufficient for a given site application, additional controls may be used in series in a “treatment train” approach. For additional information and data on the range of pollutant removal capabilities for various structural stormwater controls, see the National Pollutant Removal Performance Database (2nd Edition) available at www.cwp.org and the National Stormwater Best Management Practices (BMP) Database at www.bmpdatabase.org.

Table 5: Structural BMP expected pollutant removal efficiency (EPA)

BMP Type	Typical Pollutant Removal (percent)				
	Suspended Solids	Nitrogen	Phosphorous	Pathogens	Metals
Dry detention basins	30-65	15-45	15-45	<30	15-45
Extended detention and wet detention basins	50-80	30-65	30-65	<30	50-80
Constructed wetlands	50-80	<30	15-45	<30	50-80
Infiltration basins	50-80	50-80	50-80	65-100	50-80
Infiltration trenches	50-80	50-80	15-45	65-100	50-80
Pervious/porous pavement systems	65-100	65-100	30-65	65-100	65-100
Grassed swales	30-65	15-45	15-45	<30	15-45
Vegetated filter strips	50-80	50-80	50-80	<30	30-65
Surface sand filters	50-80	<30	50-80	<30	50-80
Other media filters	65-100	15-45	<30	<30	50-80

Source: Adapted from US EPA, 1993c

Table 6: Structural BMP expected pollutant removal efficiency (Georgia)

Structural Control	Typical Pollutant Removal (percent)				
	Total Suspended Solids	Total Nitrogen	Total Phosphorous	Fecal Coliform	Metals
Stormwater ponds	80	50	30	70*	50
Stormwater wetlands	80	40	30	70*	50
Bioretention areas	80	60	50		80
Sand filters	80	50	25	40	50
Infiltration trench	80	60	60	90	90
Enhanced dry swales	80	50	50	***	40
Enhanced wet swales	80	25	40	***	20
Filter strip	50	20	20	***	40
Grass channel	50	25	20	***	30
Organic filter	80	60	40	50	75
Underground sand filter	80	50	25	40	50
Submerged gravel wetland	80	50	20	70	50
Gravity (oil-grit) separator	40	5	5	***	***
Pervious concrete	**	50	65	***	60
Modular porous paver systems	**	80	80	***	90
Alum treatment	90	80	60	90	75
* If no resident waterfowl population is present.					
** Due to the potential for clogging, pervious concrete and modular block paver systems should not be used for the removal of sediment or other coarse particulate pollutants.					
*** Insufficient data to provide design removal efficiency.					

Source: Georgia Stormwater Manual, Vol. 2, 2001

D. Selection guide for structural stormwater controls

During the initial screening of alternative treatment controls, the following considerations are recommended (ASCE, 1998):

1. **Source controls.** Source controls should be considered as a first step in the treatment train before more expensive treatment controls are selected. Good housekeeping practices can keep pollutants out of the stormwater and supplement the subsequent removal efficiency of downstream BMPs.
2. **Design storm size.** The design storms used for sizing of water quality controls are different from those used for the design of peak discharge control from urban watersheds. For example, the pollutant load from an infrequent 25-year storm is of much less concern than the potential hydraulic damage from overbank flooding or streambank erosion. For water quality control, the small, frequent events (smaller than the 1-year storm), carry the vast majority of the annual pollutant load and annual runoff volume.
3. **Soil erosion.** The overall success of any BMP control installation is influenced by how soil erosion protection is regulated, supervised, and practiced in the upstream watershed. Higher than normal sediment loads from unstable and poorly protected urban sites will affect the performance and maintenance requirements of treatment controls.
4. **Stormwater pollutant characteristics.** Potential pollutants can be either in the particulate or dissolved form. Certain BMPs will remove only particulate materials. Other BMPs, such as wet ponds, provide physical, chemical, and biological conditions that may support improved removal of dissolved pollutants, such as nitrogen and phosphorous. While actual removal efficiency may

vary, the designer should select treatment controls that support processes likely to provide the best removal of the pollutant of concern.

5. **Multiple uses.** Consider opportunities to integrate stormwater treatment with other community objectives. Several examples are active and passive recreation, wildlife and aquatic habitat, traditional flood control, and groundwater recharge to maintain base-flow in area streams.
6. **Maintenance.** BMPs will have varying requirements for maintenance, and can range from low to high frequency and cost. All BMPs need some degree of care to operate effectively and as designed. The site design must include adequate access for the required level of maintenance and the responsible entity should be identified in conjunction with the long-term plan for the facility.

A general decision matrix based on the above factors is presented as Figure 1. This initial selection matrix should assist in narrowing the list of potential BMPs for further consideration. A more detailed screening process is described later in this manual.

E. General application control screening process

A screening process for general application structural stormwater controls is provided below. This process is intended to assist the site designer and design engineer in the selection of the most appropriate structural controls for a development site, and provides guidance on factors to consider in their location.

In general the following four criteria should be evaluated in order to select the appropriate structural control(s) or group of controls for a development:

- Stormwater treatment suitability
- Water quality performance
- Site applicability
- Implementation considerations

In addition, for a given site, the following factors should be considered and any specific design criteria or restrictions need to be evaluated:

- Physiographic factors
- Soils
- Special watershed or stream considerations

Finally, environmental regulations that may influence the location of a structural control onsite or may require a permit need to be considered.

The following selection process may be used for comparing and evaluating general application structural stormwater controls, using two screening matrices and a list of location and permitting factors. These tools are provided to assist the Engineer in selecting the initial alternative structural controls that will meet the stormwater management and design objectives for a development site or project.

1. **Overall applicability.** Through the use of the first matrix (Table 7), the site designer should evaluate and screen the overall applicability of the full set of general application structural

controls as well as the constraints of the site in question. The following are the details of the various screening categories and individual characteristics used to evaluate the structural controls.

Figure 1: Decision matrix for selection of potential treatment BMPs

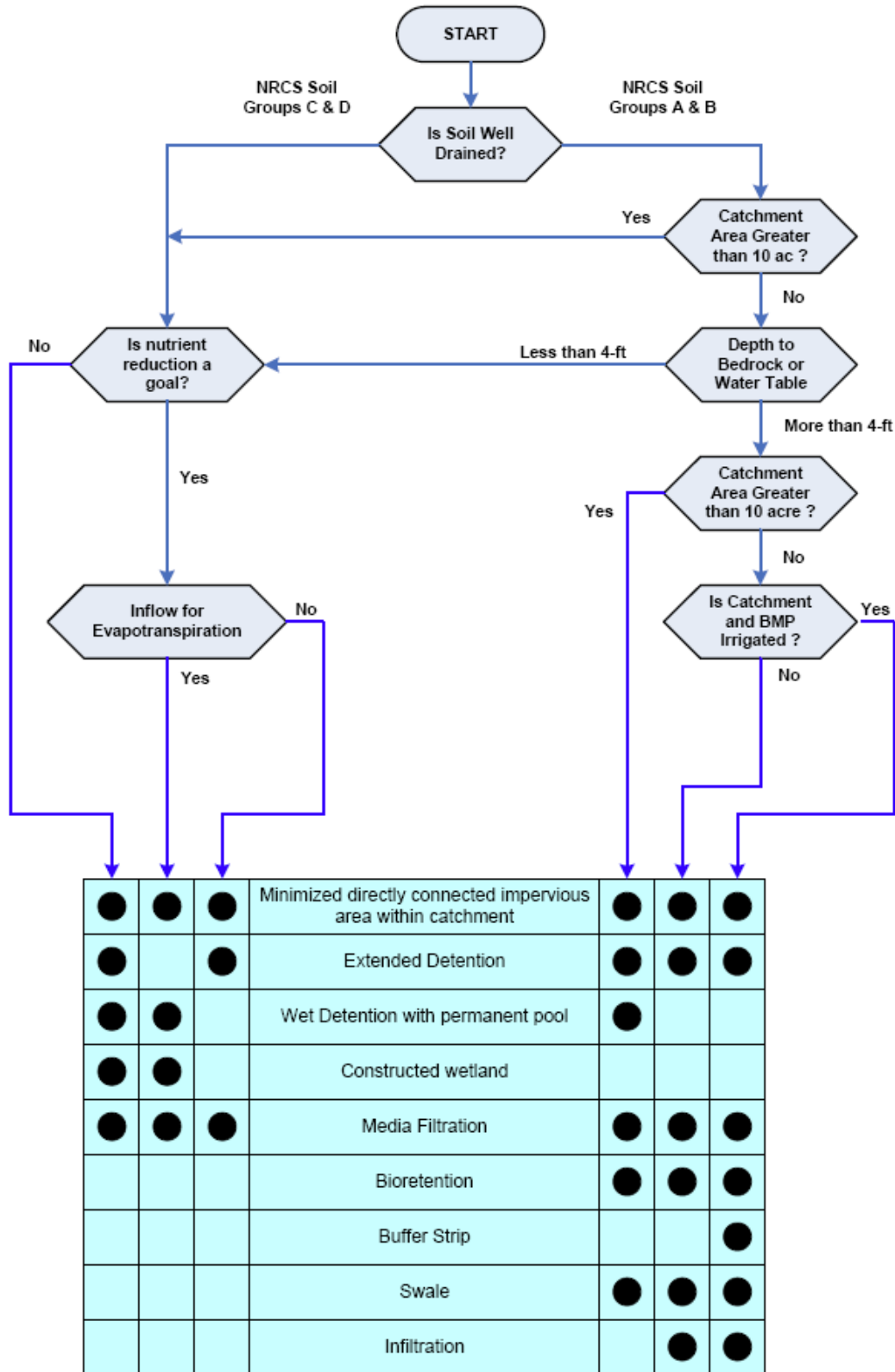

Source: Adapted from ASCE, 1998

2. **Stormwater management suitability.** The first columns of Table 7 examine the capability of each structural control option to provide water quality treatment, downstream channel protection, overbank flood protection, and extreme flood protection. A blank entry means that the structural control cannot or is not typically used to meet a unified stormwater sizing criterion. This does not necessarily mean that it should be eliminated from consideration, but rather is a reminder that more than one structural control may be needed at a site (e.g., a bioretention area used in conjunction with dry detention storage).
 - a. **Ability to treat the water quality volume.** This indicates whether a structural control provides treatment of the water quality volume (WQv).
 - b. **Ability to provide channel protection.** This indicates whether the structural control can be used to provide the extended detention of the channel protection volume (CPv). The presence of a check mark indicates that the structural control can be used to meet CPv requirements. A star indicates that the structural control may be sized to provide channel protection in certain situations, for instance on small sites.
 - c. **Ability to provide overbank flood protection.** This indicates whether a structural control can be used to meet the overbank flood protection criteria (Qp). The presence of a check mark indicates that the control can be used for peak reduction of the 25-year storm event.
 - d. **Ability to provide extreme flood protection.** This indicates whether a structural control can be used to meet the extreme flood protection criteria (Qf). The presence of a check mark indicates that the structural control can be used to provide peak reduction of the 100-year storm event.
3. **Relative water quality performance.** The second group of columns in Table 7 provides an overview of the pollutant removal performance of each structural control option, when designed, constructed, and maintained according to the design criteria and specifications in these manuals.
 - a. **Ability to provide TSS and sediment removal.** This column indicates the capability of a structural control to remove sediment in runoff. All of the general application structural controls are presumed to remove 80% of the average annual TSS (total suspended solids) load in typical urban post-development runoff (and a proportional removal of other pollutants).
 - b. **Ability to provide nutrient treatment.** This column indicates the capability of a structural control to remove the nutrients nitrogen and phosphorus in runoff, which may be of particular concern with certain downstream receiving waters.
 - c. **Ability to provide bacteria removal.** This column indicates the capability of a structural control to remove bacteria in runoff. This capability may be of particular focus in areas with public beaches, sensitive urban stream segments, or to meet water regulatory quality criteria under the Total Maximum Daily Load (TMDL) program.
 - d. **Ability to accept hotspot runoff.** This last column indicates the capability of a structural control to treat runoff from designated hotspots. Hotspots are land uses or activities with higher potential pollutant loadings. Examples of hotspots might include: gas stations, convenience stores, marinas, public works storage areas, vehicle service and maintenance areas, commercial nurseries, and auto recycling facilities. A check mark indicates that the

structural control may be used on a hotspot site, however it may have specific design restrictions. See the specific design criteria of the structural control for more details.

4. **Site applicability.** The third group of columns in Table 7 provides an overview of the specific site conditions or criteria that must be met for a particular structural control to be suitable. In some cases, these values are recommended values or limits that can be exceeded or reduced with proper design or depending on specific circumstances. See the specific criteria section of the structural control for more details.
 - a. **Drainage area.** This column indicates the approximate minimum or maximum drainage area that is considered suitable for the structural control practice. If the drainage area present at a site is slightly greater than the maximum allowable drainage area for a practice, some leeway can be permitted if more than one practice can be installed. The minimum drainage areas indicated for ponds and wetlands should not be considered inflexible limits, and may be increased or decreased depending on water availability (baseflow or groundwater), the mechanisms employed to prevent outlet clogging, or design variations used to maintain a permanent pool (e.g., liners).
 - b. **Space required.** This comparative index expresses how much space a structural control typically consumes at a site, in terms of the approximate area required as a percentage of the area draining to the control.
 - c. **Slope.** This column evaluates the effect of slope on the structural control practice. Specifically, the slope restrictions refer to how flat the area where the facility is installed must be and/or how steep the contributing drainage area or flow length can be.
 - d. **Minimum head.** This column provides an estimate of the minimum elevation difference needed at a site (from the inflow to the outflow) to allow for gravity operation within the structural control.
 - e. **Water table.** This column indicates the minimum depth to the seasonally high water table from the bottom or floor of a structural control.
5. **Implementation considerations.** The last group of columns in Table 7 provides additional considerations for the applicability of each structural control option.
 - a. **Residential subdivision use.** This column identifies whether or not a structural control is suitable for typical residential subdivision development (not including high-density or ultra-urban areas).
 - b. **Ultra-urban.** This column identifies those structural controls that are appropriate for use in very high-density (ultra-urban) areas, or areas where space is a premium.
 - c. **Construction Cost.** The structural controls are ranked according to their relative construction cost per impervious acre treated, as determined from cost surveys.
 - d. **Maintenance.** This column assesses the relative maintenance effort needed for a structural stormwater control in terms of three criteria: frequency of scheduled maintenance, chronic maintenance problems (such as clogging), and reported failure rates. It should be noted that *all* structural controls require routine inspection and maintenance.

A similar screening process is used for the Limited Application controls. The applicability matrix is included in Table 8. Additional BMP selection criteria showing restrictions for watershed area and soil type/permeability are shown in Tables 9 and 10.

Table 7: Selection and applicability of general application controls

General Application Controls									
Structural Control Category	Structural Control	Stormwater Treatment Suitability				Expected Water Quality Performance			
		Water Quality	Channel Protection	Overbank Flood Protection	Extreme Flood Protection	TSS / Sediment Removal Rate	Nutrient Removal Rate (TP/TN)	Bacteria Removal Rate	Hotspot Application
Stormwater ponds	Wet pond	✓	✓	✓	✓	80%	50% / 30%	70%	✓
	Wet ED pond	✓	✓	✓	✓				✓
	Micro-pool ED pond	✓	✓	✓	✓				✓
	Multiple ponds	✓	✓	✓	✓				✓
Stormwater wetlands	Shallow wetland	✓	✓	✓	✓	80%	40% / 30%	70%	✓
	Shallow ED wetland	✓	✓	✓	✓				✓
	Pond wetland	✓	✓	✓	✓				✓
	Pocket wetland	✓	✓						✓
Bioretention	Bioretention areas	✓	*			80%	60% / 50%	ID	✓
Sand Filters	Surface sand filter	✓	*			80%	50% / 25%	40%	✓
	Perimeter sand filter	✓	*						✓
Infiltration	Infiltration trench	✓	*			80%	60% / 60%	90%	
Enhanced Swales	Dry swale	✓	*			80%	50% / 50%	ID	✓
	Wet swale	✓	*			80%	25% / 40%	ID	✓

✓ Meets suitability criteria * Can be incorporated into the structural control in certain situations ID Insufficient data

Source: Georgia Stormwater Manual, Vol. 2, 2001

Table 7: Selection and applicability of general application controls (continued)

Structural Control Category	Structural Control	Site Applicability					Implementation Consideration			
		Drainage Area (acres)	Space Required (% of tributary Impervious Area)	Site Slope	Minimum Head Required (feet)	Depth to Water Table	Residential Subdivision Use	High Density / Ultra Urban	Capital Cost	Maintenance Burden
Stormwater ponds	Wet pond	25 min	2-3%	15% Max	6-8 ft	2 ft if hotspot or aquifer	✓		Low	Low
	Wet ED pond						✓		Low	Low
	Micropool ED pond	10 min					✓		Low	Moderate
	Multiple ponds	25 min					✓		Low	Low
Stormwater wetlands	Shallow wetland	25 min	3-5%	8% Max	3-5 ft	2 ft if hotspot or aquifer	✓		Moderate	Moderate
	Shallow ED wetland						✓		Moderate	Moderate
	Pond wetland	5 min			6-8 ft	✓		Moderate	Moderate	
	Pocket wetland				2-3 ft	Below WT	✓		Moderate	High
Bioretention	Bioretention areas	5 max	5%	6% Max	5 ft	2 feet	✓	✓	Moderate	Moderate
Sand filters	Surface sand filter	10 max	2-3%	6% Max	5 ft	2 feet		✓	High	High
	Perimeter sand filter	2 max			2-3 ft			✓	High	High
Infiltration	Infiltration trench	5 max	2-3%	10% Max	1 ft	4 feet	✓	✓	High	High
	Infiltration basin	10 max			3-ft		✓			
Enhanced swales	Dry swale	5 max	10-20%	4% Max	3-5 ft	2 feet	✓		Moderate	Low
	Wet swale	5 max			1 ft	Below WT	✓		High	Low

Source: Georgia Stormwater Manual, Vol. 2, 2001

Table 8: Selection of limited application control screening

Structural Control Category	Structural Control	Water Quality	Site Applicability		Implementation Considerations					
		Meets 80% TSS Reduction Goal	Drainage Area (acres)	Space Required (% of tributary impervious area)	Pretreatment Control	Residential Subdivision Use	High Density Ultra-Urban	Capital Cost	Maintenance Burden	Commercially Manufactured Systems Available
Biofilters	Filter strip	No*	2 max	20-25%	✓	✓		Low	Moderate	
	Grass channel	No*	5 max	10-20%	✓	✓		Low	Low	
Filtering practices	Organic filter	Yes	10 max**	2-3%			✓	High	High	
	Underground sand filter	Yes	5 max	None			✓	High	High	Yes
Wetland systems	Submerged gravel wetland	Yes	5 max**	2-3%			✓	High	High	
Hydro-dynamic devices	Gravity (oil-grit) separator	No*	1 max**	None	✓		✓	High	High	Yes
Porous surfaces	Pervious concrete ¹	No ²	5 max	Varies			✓	Medium	High	
	Modular porous paver systems ¹	No ²	5 max	Varies		✓	✓	High	High	Yes
Chemical treatment	Alum treatment systems	Yes	25 min	None				High	High	

✓ -- Meets suitability criteria
 * Provides less than 80% TSS removal efficiency. May be used in pretreatment and as part of a treatment train.
 ** Drainage area can be larger in some instances.
¹ Porous surfaces provide water quantity benefits by reducing the effective impervious area.
² Due to potential for clogging, porous surfaces should not be used for the removal of sediment or other coarse particulate pollutants.

Source: Georgia Stormwater Manual, Vol. 2, 2001

Table 9: Watershed area restrictions for BMPs

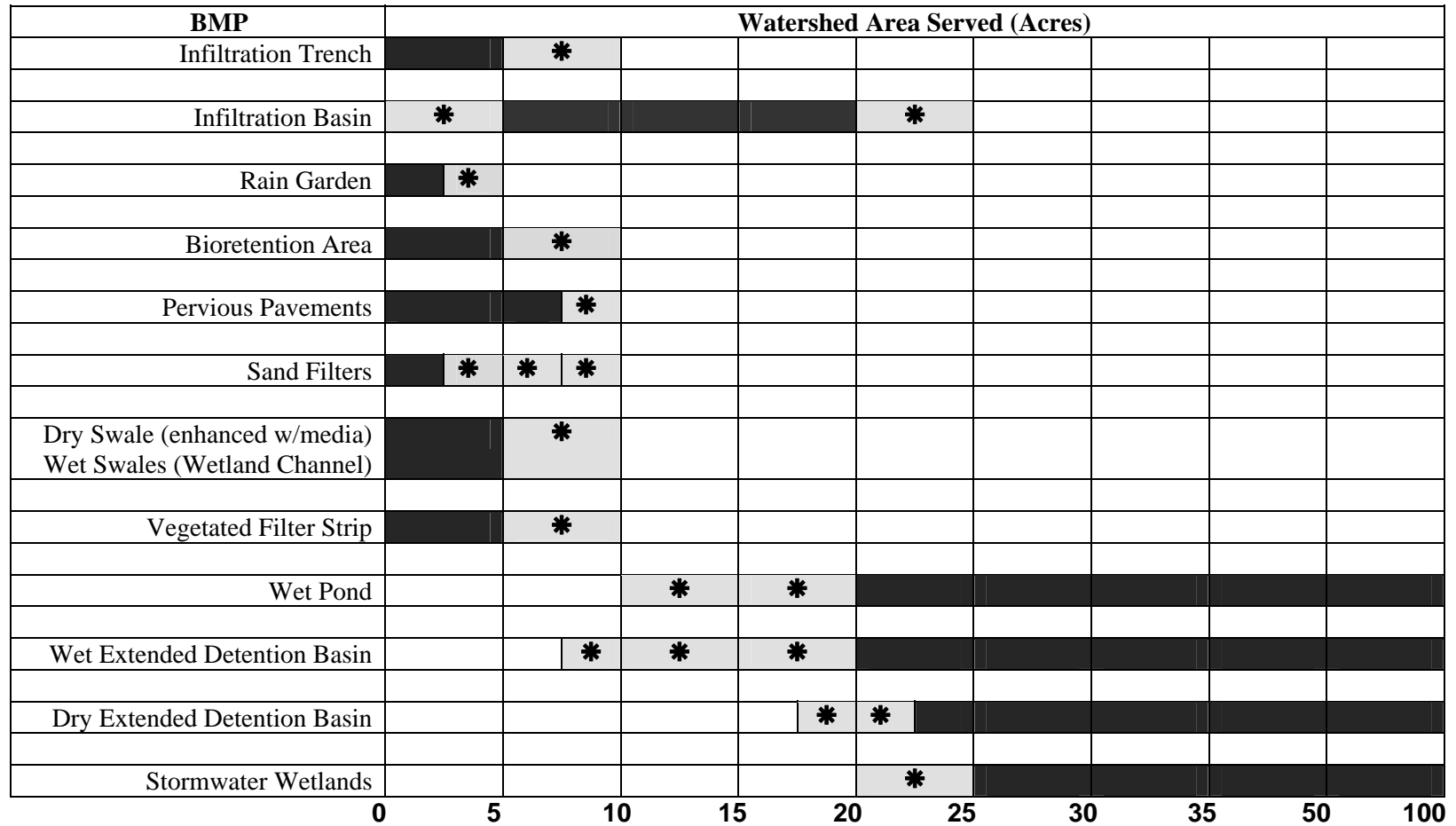

Legend	*	
	Feasible	*

Source: Adapted from Schueler, 1987

Table 10: Soil permeability restrictions for BMPs

BMP	Soil Type										
	Infiltration trench				*						
Infiltration Basin				*							
Rain Garden				*							
Bioretention Area					*	*					
Pervious Pavement				*							
Dry Swale (enhanced w/media); Wet Swales							*	*	*		
Filter Strips							*	*	*		
Wet Pond		*	*								
Extended Detention Basins		*	*								
Stormwater Wetlands		*	*								
	SAND (8.3)	LOAMY SAND (2.4)	SANDY LOAM (1.02)	LOAM (0.52)	SILT LOAM (0.27)	SANDY CLAY LOAM (0.17)	CLAY LOAM (0.09)	SILTY CLAY LOAM (0.06)	SANDY CLAY (0.05)	SILTY CLAY (0.04)	CLAY (0.02)
SOIL TYPE (MINIMUM INFILTRATION RATE, INCHES/HOUR)											

Legend		*	
	Feasible	Marginal	Not Feasible

Source: Adapted from Schueler, 1987

F. Online vs. off-line structural controls

Structural stormwater controls are designed to be either “online” or “off-line.” Online facilities are designed to receive, but not necessarily control or treat, the entire runoff volume up to the Q_p-25 or Q_f event. Online structural controls must be able to handle the entire range of storm flows. Design variants are online controls with conveyance capacity for up to the Q_p-50 , while the incremental runoff from the 100-year event is bypassed through an alternate conveyance.

Off-line facilities on the other hand, are designed to receive only a specified flow rate through the use of a flow regulator (i.e. diversion structure, flow splitter, etc). Flow regulators are typically used to divert the water quality volume (WQv) to an off-line structural control sized and designed to treat and control the WQv. After the design runoff flow has been treated and/or controlled, it is returned to the conveyance system. Figure 2 shows examples of an off-line sand filter and an online enhanced dry swale.

Figure 2: Off-line vs. online BMP configuration

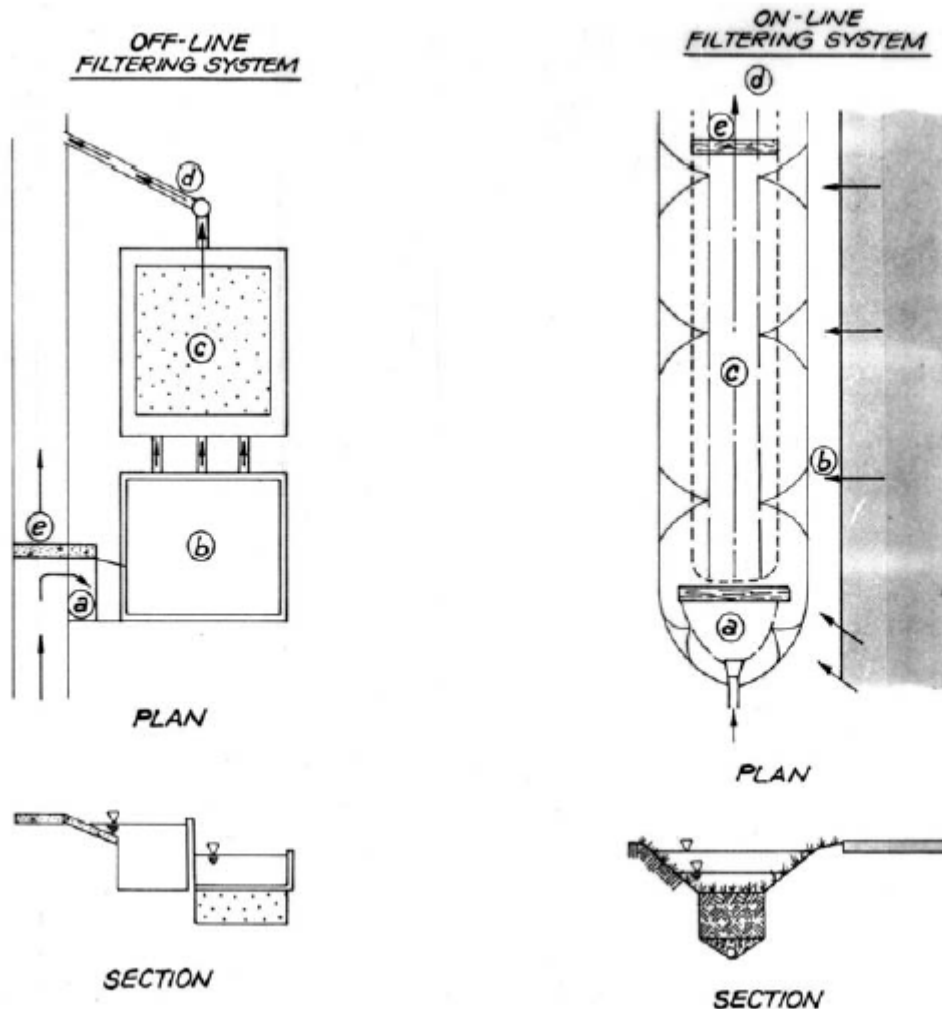

Source: Clayton and Schueler, 1996

Flow regulation to off-line structural stormwater controls can be achieved by either:

- Diverting the water quality volume or other specific maximum flow rate to an off-line structural stormwater control, or
- Bypassing flows in excess of the design flow rate.

The peak water quality flow rate (Q_{wq}) can be calculated using the procedure found in Part 2C-7.

Flow regulators can be flow splitter devices, diversion structures, or overflow structures. A number of examples are shown below.

Figure 3: Pipe interceptor diversion structure

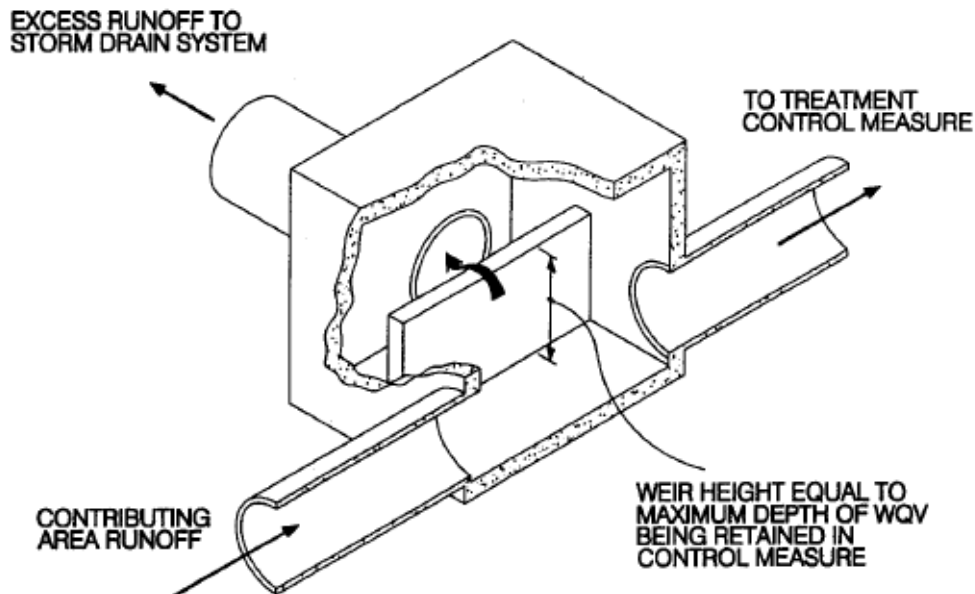

Source: City of Sacramento, 2000

Figure 4: Surface channel diversion structure

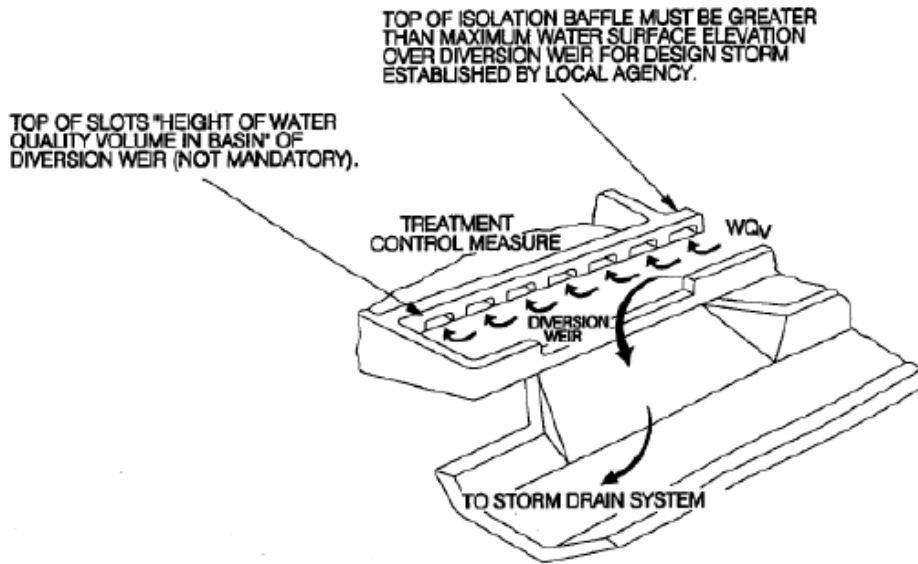

Source: City of Sacramento, 2000

Figure 5: Outlet flow regulator

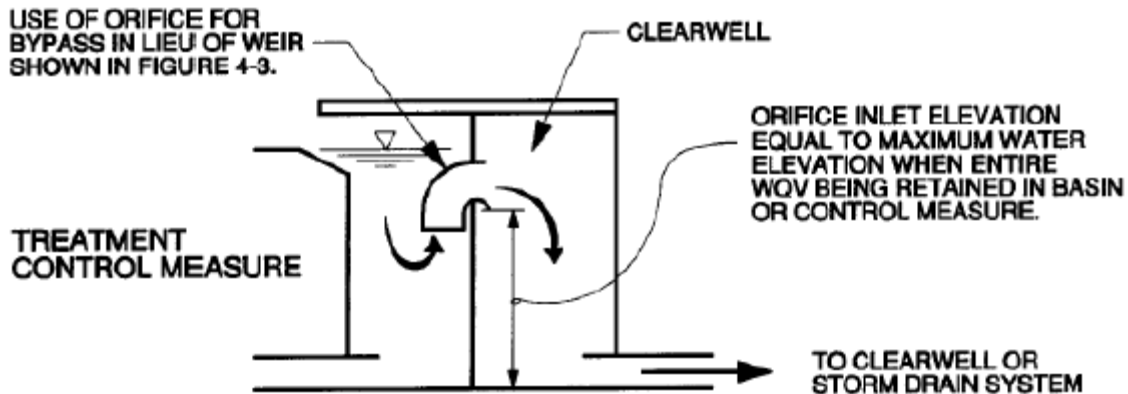

Source: City of Sacramento, 2000

G. Onsite vs. regional stormwater management

1. **Onsite stormwater management.** Using individual, onsite structural stormwater controls for each development is the typical approach for controlling stormwater quantity and quality. The developer finances the design and construction of these controls, and is initially responsible for all operation and maintenance. A potential alternative approach is for a community to install a few strategically-located regional stormwater controls in a sub-watershed rather than require onsite controls (see Figure 6).
2. **Regional stormwater management.** Regional stormwater controls are defined as facilities designed to manage stormwater runoff from multiple projects and/or properties through a local

jurisdiction-sponsored program, where the individual properties may assist in the financing of the facility, and the requirement for onsite controls is either eliminated or reduced.

Figure 6: Onsite versus regional stormwater management

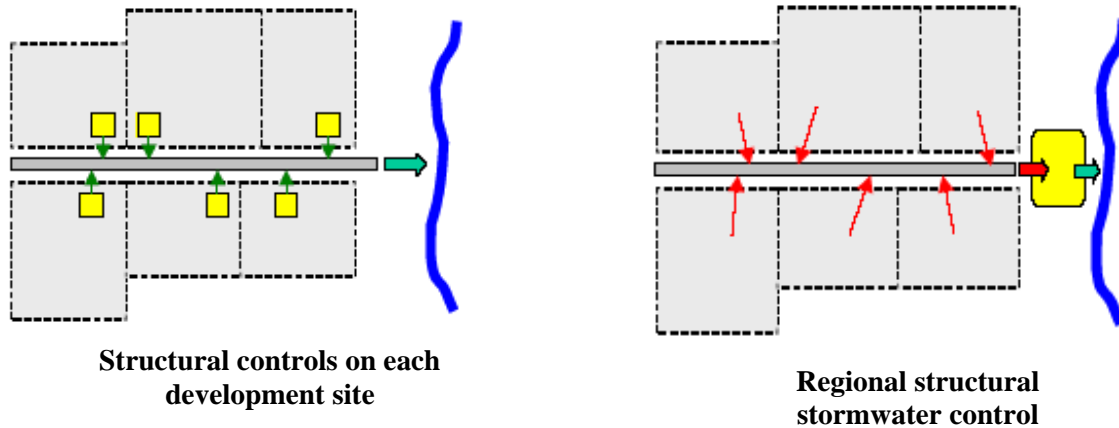

a. **Advantages of regional stormwater controls.**

- 1) **Reduced construction costs.** Design and construction of a single regional stormwater control facility can be far more cost-effective than numerous individual onsite structural controls.
- 2) **Reduced operation and maintenance costs.** Rather than multiple owners and associations being responsible for the maintenance of several stormwater facilities on their developments, it is simpler and more cost-effective to establish scheduled maintenance of a single regional facility.
- 3) **Higher assurance of maintenance.** Regional stormwater facilities are far more likely to be adequately maintained as they are large and have a higher visibility, and are typically the responsibility of the local government.
- 4) **Maximum utilization of developable land.** Developers are able to maximize the utilization of the proposed development for the purpose intended by minimizing the land normally set aside for the construction of stormwater structural controls.
- 5) **Retrofit potential.** Regional facilities can be used by a community to mitigate existing developed areas that have insufficient or no structural controls for water quality and/or quantity, as well as provide for future development.
- 6) **Other benefits.** Well-sited regional stormwater facilities can serve as a recreational and aesthetic amenity for a community.

b. **Disadvantages of regional stormwater controls.**

- 1) **Location and siting.** Regional stormwater facilities may be difficult to site, particularly for large facilities or in areas with existing development.
- 2) **Capital costs.** The community must typically provide capital construction funds for a regional facility, including the costs of land acquisition. However, if a downstream developer is the first to build, that person could be required to construct the facility and later be compensated by upstream developers for the capital construction costs and annual maintenance expenditures. Conversely, an upstream developer may have to establish temporary control structures if the regional facility is not in place before construction.

- 3) **Maintenance.** The local government is typically responsible for the operation and maintenance of a regional stormwater facility, and may need to establish a stormwater utility or some other program to fund and implement stormwater control.
 - 4) **Need for planning.** The implementation of regional stormwater controls requires substantial planning, financing, and permitting. Land acquisition must be in place ahead of future projected growth.
- c. **Disadvantages of in-stream regional facilities.**
- 1) **Water quality and channel protection.** Without onsite water quality and channel protection, regional controls do not protect smaller streams upstream from the facility from degradation and stream bank erosion.
 - 2) **Ponding impacts.** Upstream inundation from a regional facility impoundment can eliminate floodplains, wetlands, and other habitat.
- d. **Considerations for the use of regional stormwater controls.** If a community decides to implement a regional stormwater control, it must ensure that the conveyances between the individual upstream developments and the regional facility can handle the design peak flows and volumes without causing adverse impact or property damage. Full build-out conditions in the regional facility drainage area should be used in the analysis. In addition, unless the system consists of completely man-made conveyances (i.e. storm drains, pipes, concrete channels, etc.); onsite structural controls for water quality and downstream channel protection will be required for all developments within the facility's drainage area. Federal water quality provisions do not allow the degradation of water bodies from untreated stormwater discharges, and it is U.S. EPA policy to not allow regional stormwater controls that would degrade stream quality between the upstream development and the regional facility.

Further, without adequate channel protection, aquatic habitats and water quality in the channel network upstream of a regional facility may be degraded by stream bank erosion if they are not protected from bank-full flows and high velocities. Based on these concerns, both the EPA and the U.S. Army Corps of Engineers have expressed opposition to in-stream regional stormwater control facilities. In-stream facilities should be avoided if possible, and will likely be permitted on a case-by-case basis only. It is important to note that siting and designing regional facilities should ideally be done within a context of a stormwater master planning or watershed planning to be effective (See Part 2A).

H. Using structural stormwater controls in series

The minimum stormwater management standards are an integrated planning and design approach whose components work together to limit the adverse impacts of urban development on downstream waters and riparian areas. This approach is sometimes called a stormwater "treatment train." When considered comprehensively, a treatment train consists of all the design concepts and nonstructural and structural controls that work to attain water quality and quantity goals (See Figure 7).

Figure 7: Generalized stormwater treatment train



1. **Runoff and load generation.** The initial part of the train is located at the source of runoff and pollutant load generation, and consists of better site design and pollution prevention practices that reduce runoff and stormwater pollutants.
2. **Pretreatment.** The next step in the treatment train consists of pretreatment measures. These measures typically do not provide sufficient pollutant removal to meet the 80% TSS reduction goal, but do provide quantifiable water quality benefits that may be applied towards meeting the WQv treatment requirement. These measures include:
 - Use of stormwater better site design practices and/or LID site design credits to reduce WQv
 - Structural controls that provide pretreatment
 - Pretreatment facilities such as sediment fore-bays on structural controls
3. **Primary treatment and/or quantity control.** The last step is primary water quality treatment and/or quantity control (channel protection, overbank flood protection, and/or extreme flood protection). This is achieved through the use of:
 - Structural controls meeting all of the uniform sizing criteria
 - Structural controls for water quality
 - Detention structural controls for peak discharge control
4. Use of multiple structural controls in series. Many combinations of structural controls in series may exist for a site. Figure 8 provides a number of hypothetical examples of how the unified stormwater sizing criteria may be addressed by using structural stormwater controls.

Figure 8: Examples of structural controls used in series

