

Expanding the Use of Integral Abutments in Iowa

Kenneth F. Dunker
Office of Bridges and Structures
Iowa Department of Transportation
800 Lincoln Way
Ames, IA 50010
Kenneth.Dunker@dot.iowa.gov

Ahmad Abu-Hawash
Office of Bridges and Structures
Iowa Department of Transportation
800 Lincoln Way
Ames, IA 50010
Ahmad.Abu-Hawash@dot.iowa.gov

ABSTRACT

In the mid-1960s Iowa began experimenting with jointless bridges constructed with integral abutments. Later, in the 1980s, researchers at Iowa State University developed a methodology for analysis of the piles in integral abutments. The methodology determines the depth at which a pile can be considered to have a fixed support. With an established location of fixity, the pile can be checked for ductility to ensure that it can flex without damage and can be checked as a column to ensure that it can support the abutment, end span, and traffic. With the methodology, it is possible to set general policy limits on the use of integral abutments, address industry trends, and consider unusual site conditions. Based on a parameter study, Iowa recently increased the bridge length limits for integral abutments to 575 feet for concrete superstructures and to 400 feet for steel superstructures, with reductions for skew. Use of compact, Grade 50 H-piles, or deeper prebored holes permits longer end spans to 150 feet or more for steel superstructures. On a case-by-case basis, the methodology permits consideration of piles with downdrag, retaining walls near abutments, unsymmetrical site conditions, and sites with bedrock near the surface.

Use of jointless bridges reduces initial costs by eliminating bearings and expansion joints and reduces maintenance costs because there can be no damage from leaking joints. Expanding the use of jointless bridges with integral abutments has improved the overall life-cycle cost of Iowa bridges.

Key words: integral abutments—jointless bridges

INTRODUCTION

Background

A covered timber bridge had sidewalls and a roof to protect the timber superstructure from weather and decay. In a similar way, a jointless bridge deck protects the superstructure and substructure from deterioration. Integral abutments are jointless bridge components that eliminate the need for expansion joints in the deck and prevent runoff from rapidly damaging beam or girder ends, bearings, and abutments.

Iowa has minimized the use of expansion joints in bridge decks for many years. In 1939, V7 three-span steel bridge standard plans made use of continuous beams with only one deck expansion joint. In 1960, H12, H13, and H14 prestressed beam standard plans had no deck expansion joints, and in about 1965 Iowa began experimenting with integral abutments. Early experiments involved supporting abutments on timber piles with heads wrapped in carpet padding. In 1967 the bridge office issued the first integral abutment bridge length guidelines, and the office updated the guidelines in 1980. During the 1980s, Iowa State University (ISU) conducted research on steel H-pile behavior and analysis of integral abutment bridges (Greimann et al. 1987). After the research, in 1988 the Office of Bridges and Structures at the Iowa DOT issued guidelines that were in effect until 2002. The 1988 guidelines limited concrete or steel bridges to a length of 150 feet with skews to 45 degrees, to 300 feet with skews to 30 degrees, and to 500 feet with special investigation.

Typical Integral Abutment

A typical Iowa integral abutment for a continuous welded plate girder bridge is illustrated in Figure 1. The construction process begins as the contractor prebores holes and drives a single line of steel H-piles aligned for weak axis bending (although the piles may be skewed up to 30 degrees to align with the abutment). The contractor then cuts off the piles so that they will project into the abutment two feet, thereby ensuring a fixed pile head. To prevent loss of soil below the abutment, the contractor fills the prebored holes with bentonite slurry. Next, the contractor places formwork and reinforcement and casts the abutment footing. After the abutment footing cures, the contractor erects girders on three-inch deep S-shapes or steel bars. Finally, when additional formwork and reinforcement are in place, the contractor casts the end diaphragm with the deck. Casting the end diaphragm and deck makes the pile-to-beam or pile-to-girder connection rigid, causing the piles and superstructure to behave as a continuous rigid frame.

Research

At the time Iowa began experimenting with integral abutments, at least one engineer in the bridge office performed moment distribution analyses of the continuous pile-beam frame. Performing the analyses undoubtedly raised questions about the behavior of the piles in the frame, and, to answer the questions, Iowa initiated several research projects in the 1980s that were completed by Iowa State University civil engineering faculty.

ISU researchers first conducted field tests of steel H-piles and laboratory tests of model piles that they correlated with finite element analyses. The finite element analyses modeled a pile with beam elements and vertical and horizontal soil springs. The researchers addressed the questions of pile ductility and column capacity and eventually developed hand computation examples for checking a skewed integral abutment pile under simplified assumptions for superstructure behavior. Because the AASHTO standard specifications (AASHTO 1983) did not include information for pile ductility and weak axis bending, the

researchers developed their methodology from additional information in the engineering literature and the American Institute of Steel Construction, Inc. allowable stress design specifications (AISC 1978).

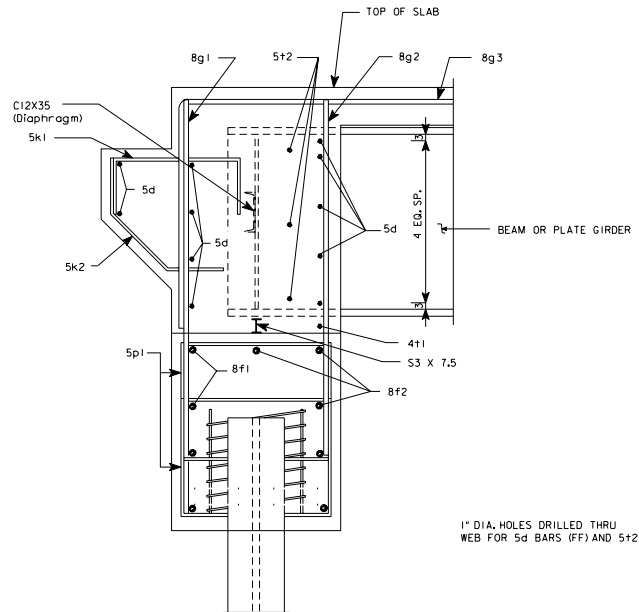

Figure 1. Longitudinal cross-section through an Iowa integral abutment for a steel girder bridge

EQUIVALENT CANTILEVER PILE MODEL

For an analysis of an integral abutment bridge, the ISU researchers proposed a simple equivalent cantilever model (Greimann et al. 1987). In the model, the pile may be either pinned or fixed at the head. The pinned-head model is appropriate for a timber pile head wrapped in carpet padding, and the fixed-head model illustrated in Figure 2 is the appropriate choice for the typical Iowa integral abutment supported by steel H-piles.

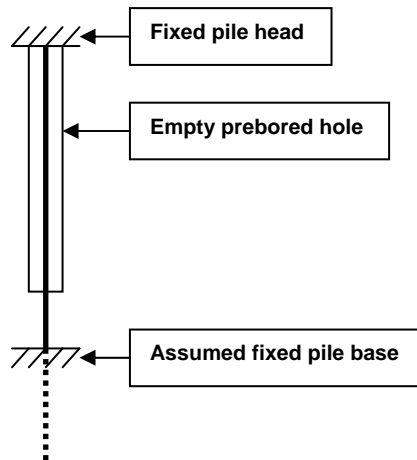

Figure 2. Fixed-head equivalent cantilever pile model

In the model, the pile may be embedded in soil over its full height or the upper portion may be freestanding in a prebored hole, the typical condition. In Iowa practice at various times, the prebored hole has been empty, filled with loose sand, or filled with bentonite slurry, but for the pile model, the hole is always assumed to be empty because any weak fill offers little support to the pile.

The equivalent cantilever pile is assumed to be fixed at some depth in the soil. Location of the assumed cantilever fixed end depends on prebored hole depth and soil properties and also depends on whether the equivalent cantilever length is being evaluated for horizontal stiffness, bending moment, or buckling of the pile. The ISU researchers developed a trial and error procedure for determining the assumed depth to fixity, which usually determines a distance in the range of three to five feet below the bottom of a prebored hole. The equivalent cantilever pile then can be checked for ductility and column capacity. The ductility check is necessary if the bridge is relatively long and its expansion or contraction will cause inelastic bending in the pile.

Whether a pile is sufficiently ductile is based on a comparison of rotation capacity and rotation demand at an inelastic hinge. For design purposes, the researchers added a safety factor to the rotation capacity.

Because the pile in an Iowa integral abutment is expected to bend primarily about its weak axis, the width-to-thickness proportion of the flanges is important. The pile has the greatest capacity to bend inelastically without distortion if the flanges are compact, a designation that indicates the pile can reach its full plastic moment and sustain an amount of inelastic rotation at the plastic hinge location without local buckling.

The basic rotation demand for AASHTO standard specifications Load Group IV, which includes temperature effects, is illustrated in Figure 3. In their methodology, ISU researchers also included an approximation for live load rotation of the end span in their ductility check. Because of the approximation, the check uses only the Δ dimensioned in the figure.

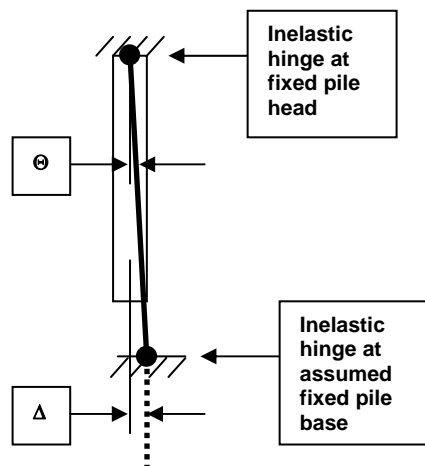

Figure 3. Rotation demand in the fixed-head equivalent cantilever model

Except for short bridges, Iowa places an integral abutment pile in a prebored hole filled with bentonite, which is assumed neither to load nor offer lateral bracing to the pile. Therefore, it is conservative to assume that the pile is unsupported between the bottom of the abutment and the assumed location of fixity

below the prebored hole. The pile can then be checked as a column for stability and yield according to the usual allowable stress design procedure.

Under AASHTO standard specifications Load Group I, the basic dead and live load case, the column loading is obvious. There will be an axial force due to all dead, live, and impact loads on the pile and a moment from the end span due to loads that occur after the end diaphragm is cast with the deck, which include the dead load applied after deck is cast, live load, and impact load, as shown in Figure 4a.

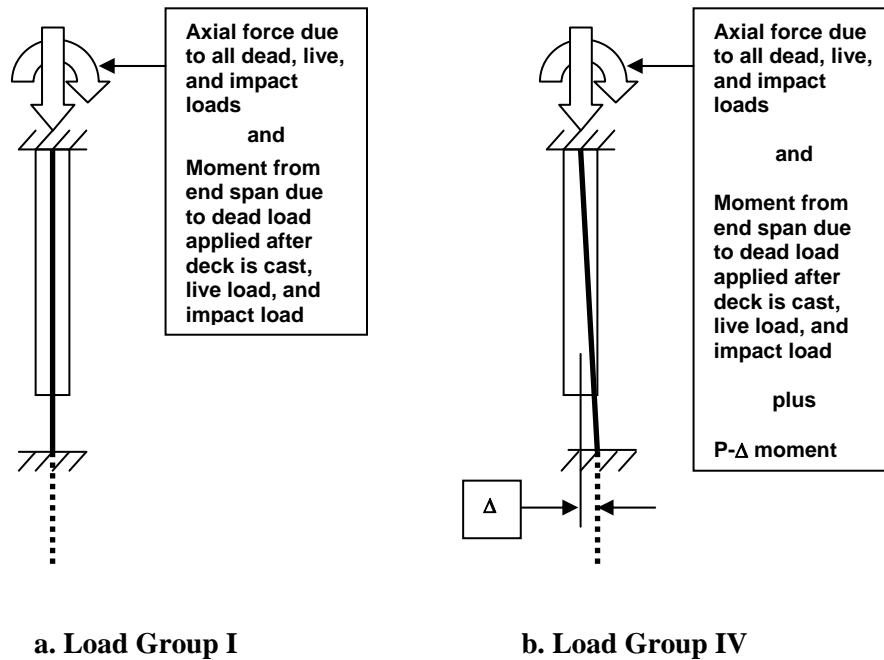

Figure 4. Loading in the fixed-head equivalent cantilever model

Under Load Group IV, the thermal moment requires consideration. If the pile is limited to elastic stresses, it will not be able to sustain much horizontal movement and an integral abutment bridge will have a very limited permissible length. The ISU researchers termed this approach Alternative 1. It is appropriate for timber piles.

Because steel H-piles have the capacity to deform inelastically, the ISU researchers also suggested a different approach, Alternative 2. Assuming that the pile in the equivalent cantilever model hinges inelastically to accommodate the extreme thermal expansion or contraction of the bridge, the pile will be displaced, but the longitudinal strains in the pile at the plastic hinge locations that are caused by the expansion or contraction of the bridge superstructure are treated as residual strains that do not affect the strength of the pile. In the displaced condition, the moment due to thermal effects will be limited to a secondary moment, the product of the axial force and half the horizontal displacement, shown in Figure 4b. Only half the horizontal displacement is used because of the fixed-fixed end conditions in the fixed-head pile model. The secondary $P-\Delta/2$ moment is much smaller than the primary elastic moment, due to abutment displacement, and allows a greater bridge length.

With Alternative 2, there are several fatigue considerations. First, there is the high-stress–low-cycle condition caused by annual thermal expansion and contraction of the bridge. Second, there is a low-

stress–high-cycle condition caused by daily thermal expansion and contraction. Third, there is a low-stress–high-cycle fatigue condition caused by live and impact loads on the end span. University of Minnesota researchers recently examined the combined effects of the first two conditions for H-piles in weak-axis bending and concluded that the conditions usually need not be considered (Huang et al. 2004). ISU researchers completing a new integral abutment study are recommending use of American Institute of Steel Construction seismic compact section criteria in design, in order to consider loss of local buckling capacity under the first condition (Abendroth and Greimann 2005; AISC 2002).

Present AASHTO allowable fatigue stress for the base metal in the pile is 24 ksi for more than 2 million cycles. Bending stresses in the pile due to the third condition, fluctuating live plus impact load on the end span, are unlikely to exceed this value if the pile is required to meet ordinary service load column checks. Thus, successful column checks will serve indirectly as an approximate check for this fatigue condition. Evidently, there is no known field evidence to date of fatigue damage for any of the three conditions.

The column checks need to be performed for both AASHTO standard specifications Load Groups I and IV. Load Group I requires that computed stresses be checked against allowable stresses without increase, but Load Group IV permits a 25% allowable stress increase. In general, Load Group I column checks will limit the length of end spans, and Load Group IV checks will limit the length of the bridge.

APPLICATION OF MODEL TO OVERALL POLICY

Although the 1988 Iowa DOT bridge length guidelines permitted integral abutments for about two-thirds of Iowa bridges, experience in the field suggested that integral abutments be used for as many bridges as possible. In cases where integral abutment bridges were constructed with lengths and/or skews greater than the guidelines, those bridges were performing well. In cases where integral abutments were not used, deck expansion joints were difficult to install and maintain. In some cases, bearings and beam or girder ends were deteriorating due to deicer runoff through poorly performing deck expansion joints.

If the equivalent cantilever model and its assumptions are accepted, it is possible to develop policy and consider options to expand the use of integral abutments. The ductility and column checks include a limited number of variables that can be explored with the goal of improving the checks.

Consider the ductility check first. Rotation capacity will be at its maximum if the pile section is compact. Due to the use of scrap steel in electric furnaces, most H-piles produced today have an actual yield stress of 50 ksi, regardless of specification. This higher yield stress, however, requires stockier flanges for a section to meet the compact designation. To ensure that piles are compact at 50 ksi, Iowa now requires HP 10x57 piles for standard integral abutments, except for continuous concrete slab bridges that have lower rotation demand than beam or girder bridges.

Ductility demand depends on the rotation, Θ , shown in Figure 3. This rotation could be reduced if the thermal expansion or contraction, Δ , were reduced. A steel superstructure could be changed to concrete to reduce Δ , but that change is seldom an option in practice. However, if the depth to assumed pile fixity is increased, the rotation demand will be reduced. It is relatively easy and inexpensive to deepen the prebored hole to move the location of assumed fixity downward, and improved ductility is one reason Iowa increased the standard prebored hole depth to 10 feet.

Now consider the column checks. Basically those checks compare computed and allowable axial and bending stresses, as indicated in the simplified equations in Figure 5. Equation (1) checks column stability, and Equation (2) checks yield at points of support. To improve the first part of the each check,

the computed axial stress, f_a , could be reduced by increasing the number of piles, which will generally have minimal cost. Another option for the stability check would be to increase the allowable axial stress, F_a , by specifying Grade 50 steel rather than Grade 36. Based on driving stresses, Iowa has made the change to Grade 50 and now is considering its beneficial effect on integral abutment policy.

$$\frac{f_a}{F_a} + \frac{C_m f_b}{\left(1 - \frac{f_a}{F_c}\right) F_b} \leq 1.0 \quad \text{Equation (1)}$$

$$\frac{f_a}{0.472F_y} + \frac{f_b}{F_b} \leq 1.0 \quad \text{Equation (2)}$$

Figure 5. Simplified combined stress equations

The second part of the column checks compares computed bending stress with allowable bending stress. The computed bending stress, f_b , could be reduced with a stiffer superstructure. However, a stiffer superstructure generally would require deeper beams or girders or a shorter end span, neither of which is desirable in practice. A better option is deeper prebored holes that will increase the flexibility of the piles and cause less moment. Deeper prebored holes, however, will reduce the allowable axial stress, so there is a limit to this option. Increasing the number of piles will also reduce the bending stress. In the second portion of the bending stress check, the allowable bending stress, F_b , can be increased with a change from Grade 36 to Grade 50 steel.

To set a general policy for integral abutments in 2002, the Office of Bridges and Structures set several parameters. These parameter decisions included the use of Grade 36 HP 10x42 piles for 6-ksi axial loading, 10-foot-deep prebored holes, a 45-degree limit for bridge skew, and very stiff clay as a conservative soil condition. These basic decisions along with temperature ranges and typical superstructure properties led to the end span and bridge length limits in the present design manual. Later, the design manual was revised to change the standard pile shape to HP 10x57 for prestressed concrete beam and steel plate girder bridges (OBS 2005). The HP 10x57's ductility was checked for a yield stress of 50 ksi, which did not affect the end span and length limits.

The standard policy length and skew limits are shown in Figure 6, along with data points for a group of recent overhead bridges. Based on bridge length, the 1988 policy limits envelop about 70% of the bridges, and the 2002 policy limits envelop nearly 90%. The exact percentage is unknown because the 2002 policy limits also include an end span length limit, and therefore some two-span steel girder bridges do not qualify for integral abutments, even though they do not exceed the bridge length and skew limits.

With the simple pile model and engineering judgment, since 2002 the Office of Bridges and Structures has set and adopted policy for use of integral abutments. These policy changes include the following:

- Compact pile sections
- Deeper prebored holes
- Separate length limits for concrete beam and steel girder superstructures
- Increased length limits: to 575 feet for concrete bridges and to 400 feet for steel bridges without skew
- End span length limits

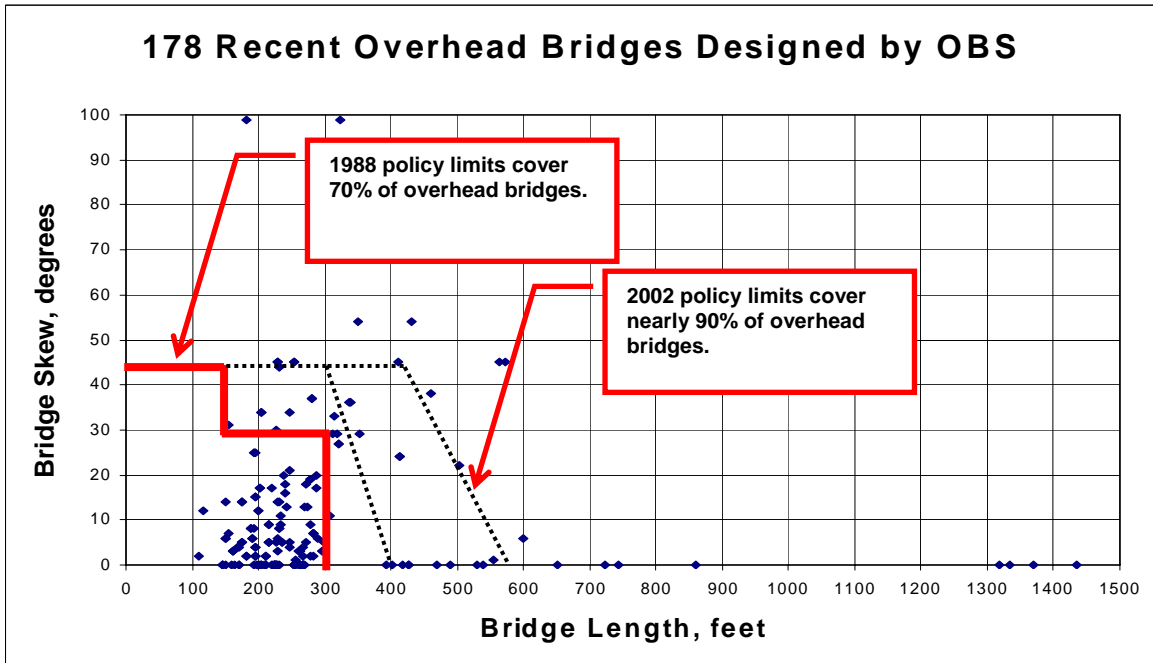

Figure 6. Bridge length and skew limits overlaid on recent overhead bridges

A parameter study for an increase in specified yield strength from 36 ksi to 50 ksi indicated that the present bridge length limits could theoretically be doubled. Ductility would be the controlling check. However, at the increased bridge lengths the annual temperature movement at each abutment would have a range of four inches or more, possibly too much to accommodate with simple pavement joint details. Therefore, it is unlikely that the Office of Bridges and Structures will increase length limits to the full theoretical limits as a general policy.

APPLICATION OF MODEL TO SPECIAL CASES

Long End Spans

The downtown Des Moines weathering steel overpasses for the I-235 rebuilding project in some cases clashed with the 2002 policies. Because the two-span overpasses are relatively short, they are not limited by length policy, but steel end spans of about 150 feet exceed the 2002 extended policy limit of 125 feet with 15-foot-deep prebored holes.

The I-235 weathering steel bridges with long end spans were checked on a case-by-case basis, and the Office of Bridges and Structures usually approved those with minimal skews. The individual checks allowed consideration of the specific design loads, superstructure stiffness, and actual soil conditions, all of which were typically favorable factors. In some cases, the individual checks required minimum-cost design modifications, such as more piles or deeper prebored holes. If Grade 50 piles had been considered, some of the modifications would have been unnecessary.

Downdrag

If embankments need to be constructed without adequate time for settlement to occur, or if abutment piles penetrate a soft cohesive layer that will compress under the weight of an embankment, the abutment piles need to be designed for downdrag. Prebored holes filled with bentonite relieve downdrag in the upper region of the piles stressed by movement of the abutment. Therefore, downdrag need not restrict use of integral abutments. An I-35 integral abutment bridge designed for downdrag by Shuck-Britson, Inc. is shown in Figure 7. Deep compressible soil layers, coupled with new abutment fills of significant magnitude, caused major downdrag loads on the abutment piles. Large 14-inch H-piles in 15-foot prebored holes accommodated the downdrag loads and allowed integral abutment movement without overstressing the piles.

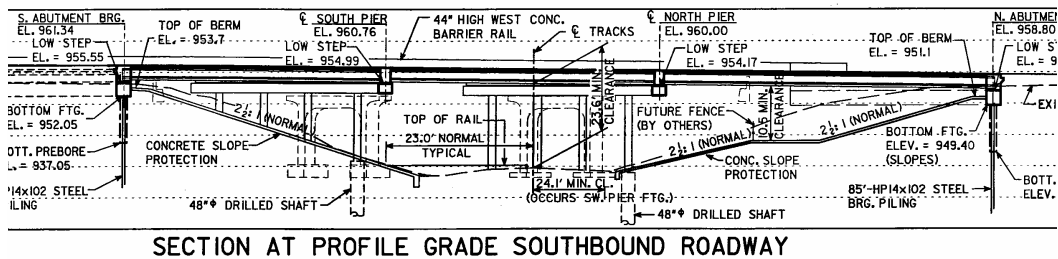

Figure 7. Southbound I-35 bridge over Union Pacific Railroad

Retaining Walls

Although most Iowa overpass bridge sites permit a sloping berm up to the abutment, in some cases there is insufficient room for the berm, and a retaining wall is necessary. If a retaining wall is placed in front of the integral abutment piles, the piles could cause additional pressure on the wall as they flex with the horizontal movement of the superstructure. As illustrated in Figure 8 (bridge designed by HDR, Inc.), to avoid the additional pressure the piles may be placed inside corrugated metal pipe (CMP) sleeves sufficiently large so that the piles can move without contacting the pipes. Pipes are filled with bentonite so they serve as cased, prebored holes. If the assumed point of pile fixity falls within the length of the CMP sleeves, the sleeves may be partially filled with saturated sand.



Figure 8. Piles in corrugated metal pipe sleeves for MLK Parkway bridge over I-235

Bedrock

If bedrock is relatively close to the surface, abutment piles may not have adequate length to flex at both abutments. If one abutment must be founded directly on bedrock but there is sufficient depth for piles to flex at the other abutment, the abutment on bedrock may simply be considered the center of the bridge. Piles at the other abutment can be checked for thermal movement based on the entire length of the bridge, rather than half the length. When bedrock is too close for the methodology that determines the assumed location of fixity, piles can be set in concrete in holes cored in the rock, as shown in Figure 9 (bridge designed by Calhoun-Burns and Associates, Inc.). The concrete sockets determine the location of fixity, and the piles can then be checked for ductility, stability, and yield.

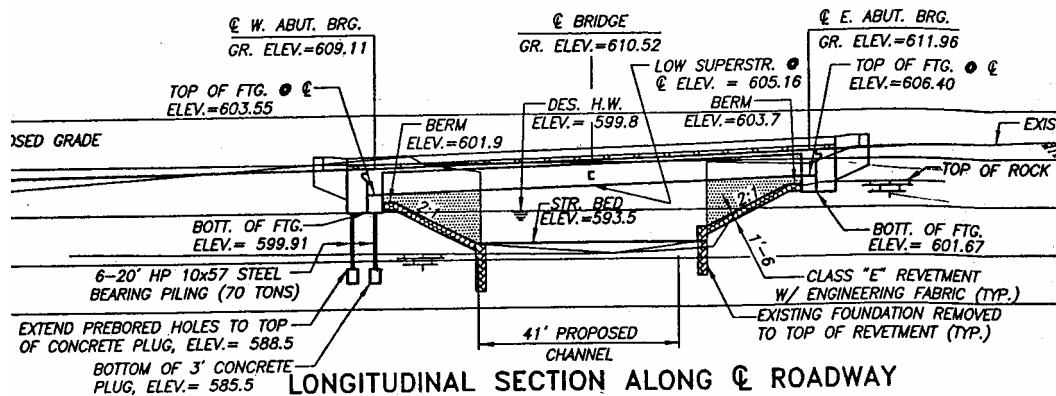

Figure 9. Van Buren County Road J56 over Flatrock Creek

SPECIAL CASES BEYOND THE MODEL

Sensitive Adjacent Structures

Occasionally, there are fragile or historic structures near the bridge site that could be damaged directly from pile driving vibration or indirectly from soil settlement caused by the vibration. In those cases, it is possible to place a drilled shaft as a support for each integral abutment pile as shown in Figure 10 (bridge designed by Parsons Transportation Group). A pile oriented for weak axis bending is simply embedded in the top of a drilled shaft, and the condition is similar to concreting piles in rock. The piles are made sufficiently long to flex with expansion and contraction of the bridge. For this foundation structure, the simple pile model is useful only for preliminary design; the structure should be analyzed in a more comprehensive manner.

SUMMARY

The simple cantilever pile model developed by ISU researchers is useful, not only for setting general policy, but also for considering special design conditions. The model has allowed the Iowa DOT to increase length limits for integral abutment bridges and thus expand the use of jointless bridges. The pile model has also allowed the use of integral abutment bridges for cases where downdrag is a concern and where bedrock is relatively close to the surface. Creative details such as placing piles in corrugated metal pipe sleeves and supporting piles with drilled shafts has further expanded the use of integral abutments.

Use of jointless bridges can reduce initial costs by eliminating expansion joints and bearings. The first cost of expansion joints and bearings is equivalent to several piles per abutment, which encourages the option of adding piles to make integral abutments feasible. Jointless bridges reduce maintenance costs because there can be no damage to beam ends or bearings due to leaking joints. Expanding the use of jointless bridges with integral abutments to longer bridges, longer end spans, and unusual site conditions has improved the overall life-cycle cost of Iowa bridges.

ACKNOWLEDGMENTS

The authors thank William Tucker, PE in the Office of Bridges and Structures at the Iowa DOT for his studies of applications of the equivalent cantilever pile model in the mid-1990s and Dr. Robert Abendroth, PE for his permission to cite the draft of the ISU integral abutment research report. The authors also thank the engineering consultants named in the text describing figures 7 through 11 for their innovative applications of integral abutments.

REFERENCES

- Abendroth, R.E. and L.F. Greimann. 2005. *Field Testing of Integral Abutments, HR-399*. Ames, Iowa: Center for Transportation Research and Education, Iowa State University. (This report was in draft form when the conference paper was submitted.)
- American Association of State Highway and Transportation Officials (AASHTO). 1983. *Standard Specifications for Highway Bridges, Thirteenth Edition*. Washington, DC: American Association of State Highway and Transportation Officials.
- American Institute of Steel Construction, Inc. (AISC). 1978. *Manual of Steel Construction, Eighth Edition*. Chicago: American Institute of Steel Construction, Inc.
- American Institute of Steel Construction, Inc. (AISC). 2002. *Seismic Provisions for Structural Steel Buildings*. Chicago: American Institute of Steel Construction, Inc.
- Greimann, L.F., R.E. Abendroth, D.E. Johnson, and P.B. Ebner. 1987. *Pile Design and Tests for Integral Abutment Bridges, Final Report and Addendum, HR-273*. Ames, Iowa: Iowa State University College of Engineering and Iowa Department of Transportation.
- Huang, J., C.E. French, and C.K. Shield. 2004. *Behavior of Concrete Integral Abutment Bridges, Final Report*. St. Paul, Minnesota: University of Minnesota Department of Civil Engineering and Minnesota Department of Transportation.
- Iowa Department of Transportation, Office of Bridges and Structures (OBS). 2005. *Bridge Design Manual*. Ames, Iowa: Office of Bridges and Structures, Iowa Department of Transportation.